



**Diogo Vala
Correia**

**Arquitetura EPCGlobal: Implementação de Estante
Inteligente para Gestão de Inventário**

**EPCGlobal Architecture: Smart Shelf
Implementation for Retail Inventory Management**



**Diogo Vala
Correia**

**Arquitetura EPCGlobal: Implementação de Estante
Inteligente para Gestão de Inventário**

**EPCGlobal Architecture: Smart Shelf
Implementation for Retail Inventory Management**

*“Science is what we have learned about how to keep from fooling
ourselves”*

— David Deutsch



Universidade de Aveiro
2021

**Diogo Vala
Correia**

**Arquitetura EPCGlobal: Implementação de Estante
Inteligente para Gestão de Inventário**

**EPCGlobal Architecture: Smart Shelf
Implementation for Retail Inventory Management**

Dissertação apresentada à Universidade de Aveiro para cumprimento dos requisitos necessários à obtenção do grau de Mestre em Engenharia Eletrónica e Telecomunicações, realizada sob a orientação científica do Doutor José Alberto Gouveia Fonseca, Professor associado do Departamento de Eletrónica, Telecomunicações e Informática da Universidade de Aveiro, e coorientação do Doutor Paulo Jorge de Campos Bartolomeu, Investigador Doutoramento do Instituto de Telecomunicações de Aveiro.

Dedico este trabalho aos meus pais, por tudo o que me possibilitaram.

o júri / the jury

presidente / president

Professor Doutor António Guilherme Rocha Campos

Professor Auxiliar do Departamento de Eletrónica, Telecomunicações e Informática da Universidade de Aveiro

vogais / examiners committee

Professor Doutor António João Nunes Serrador

Professor Adjunto do Departamento de Engenharia Eletrónica e Telecomunicações e de Computadores do ISE de Lisboa (arguente)

Professor Doutor José Alberto Gouveia Fonseca

Professor Associado do Departamento de Eletrónica, Telecomunicações e Informática da Universidade de Aveiro (orientador)

agradecimentos / acknowledgements

Aos meus pais, os sacrifícios que por mim fizeram, por tudo o que me possibilitaram, e por me proporcionarem o melhor que podiam, um eterno obrigado.

Aos meus avós, pelo amor e apoio incondicional que sempre expressaram, por serem as únicas pessoas que nunca esperaram mais do que partilhar momentos e alegrias, não existem palavras para expressar o meu carinho.

Aos amigos que encontrei neste percurso académico, pelo companheirismo e sofrimento que compartilhámos, um profundo obrigado pelo apoio que tornou este percurso suportável.

Ao Professor Doutor José Alberto Fonseca, pela orientação e apoio durante todo este período, que me permitiu seguir os meus objetivos com toda a liberdade que poderia pedir.

A toda a comunidade científica que me fez crescer e a olhar para a vida de forma humilde, por me proporcionarem destreza para interpretar o mundo sem cair na ignorância de mim mesmo.

A todos os meus amigos, família e outros com quem partilhei a vida, um fervoroso agradecimento e que muito mais possamos partilhar.

Por fim, realço o apoio financeiro por parte do Instituto de Telecomunicações de Aveiro, que suportou os custos deste trabalho na sua integridade.

Palavras Chave

RFID, UHF, estante, inteligente, EPCGlobal, EPC, Fosstrak.

Resumo

A gestão da cadeia de distribuição evoluiu significativamente ao longo dos anos. Tornou-se mais digitalizada e automatizada, fundamentalmente mudando a forma como produtos são comercializados, distribuídos e administrados. Esforços têm sido feito para desenvolver e padronizar tecnologias, de modo a promover uma cadeia de distribuição mais otimizada, criar visibilidade, controlar os níveis de estoque, e prever flutuações do mercado. Ainda assim, os esforços na integração da cadeia de distribuição parecem terminar nos pontos de venda ao cliente.

Esta dissertação apresenta um estudo sobre estantes inteligentes baseadas em RFID, aplicadas a pontos de venda e almoxarifado, seguindo tecnologias e padrões utilizados na cadeia de distribuição, para atingir uma integração completada da rede de abastecimento. A dissertação começa por apresentar RFID e seus princípios, seguido por uma visão geral da coleção de tecnologias da arquitetura da *EPCGlobal*, atualmente usada na cadeia de distribuição, e o estado da arte das estantes e prateleiras inteligentes baseadas em RFID.

Em seguida, apresenta uma análise das opções de implementação, configurações de hardware e propostas de implementação para produto real. Conclui apresentando uma implementação e testes do sistema de gerenciamento de inventário, usando componentes genéricos de UHF RFID disponíveis no mercado e software de código aberto, integrado em estantes genéricas de alumínio/MDF para armazéns.

Keywords

RFID, UHF, smart, shelf, EPCGlobal, EPC, Fosstrak.

Abstract

Supply chain management has evolved remarkably over the years. It became more digitized and automated, fundamentally changing how products are traded and managed. Efforts have been made in developing and establishing a collective of technologies and standards, to promote a leaner supply chain and create visibility for trading partners to control stock levels and predict market fluctuations. Even so, endeavors seem to stop at the point-of-sale supply chain integration.

This work presents a study on RFID smart shelves applied to point of sale and retail stockroom, following technologies and standards used in supply chain, to attain a top-down integration. The dissertation starts by introducing the RFID technology and its principles, followed by an examination of the *EPCGlobal Architecture Framework* collection of technologies, currently used in supply chain, and state of the art of RFID smart shelves.

It follows by presenting an analysis of implementation options, hardware configurations and product implementation propositions. Concludes by presenting a working crude management system implementation and tests, using off-the-shelf UHF RFID hardware components and available open-source software, integrated on typical aluminum/MDF shelves for warehouse storage.

Contents

Contents	i
List of Figures	v
List of Tables	vii
Glossary	ix
1 Introduction	1
1.1 Background and Motivation	1
1.2 Scope	2
1.3 Outline	2
2 Basic principles of RFID	5
2.1 Contextualization	5
2.2 Radio Frequency Identification (RFID) System	6
2.2.1 Components	7
2.3 Electromagnetic Concepts	7
2.3.1 <i>Near-field</i>	8
2.3.2 <i>Far-field</i>	8
2.3.3 Boundaries	9
2.4 Tag	10
2.4.1 Data Quantities	11
2.4.2 Power Supply	11
2.4.3 Coupling	13
2.4.4 RFID Technologies	15
2.5 Reader	17
2.6 Reader Antenna	18
2.6.1 Radiation pattern	18
2.6.2 Polarization	19

3	EPCglobal Architecture Framework	21
3.1	Context	21
3.1.1	Standardization Efforts	21
3.1.2	Current Problems	22
3.1.3	GS1 and EPCglobal	23
3.2	Overview	23
3.2.1	Activities	24
3.2.2	Brief	24
3.3	Generation 2 Ultra High Frequency (UHF) Tag	27
3.3.1	Memory	28
3.4	Electronic Product Code (EPC)	31
3.4.1	EPC in EPCGlobal Architecture Framework	31
3.4.2	Relationship between EPCs and GS1 keys	32
3.4.3	SGTIN	33
3.4.4	Binary Encoding	34
3.5	Low Level Reader Protocol (LLRP)	37
3.5.1	Design Requirements	37
3.5.2	Connection Details	37
3.5.3	Operation	37
3.5.4	Specification (Spec)	39
3.5.5	Application Flow	42
3.6	Filter and Collection (F&C)	42
3.6.1	Responsibilities	43
3.7	Application Level Events (ALE)	43
3.7.1	Specifications and Reports	44
3.8	Capture Application	45
3.9	EPC Information Services (EPCIS)	46
3.9.1	Data Model and Core Business Vocabulary (CBV)	46
3.9.2	Event types	48
3.9.3	Capture and Query Interfaces	49
4	RFID Smart Shelves	51
4.1	Commercial Solutions	51
4.1.1	Keonn: AdvanShelf™	52
4.1.2	CribMaster: AccuCab and AccuDrawer	52
4.1.3	Fabmatics: RFID Rack	53
4.2	Academic solutions	54

5	Contextualization and Development Plan	55
5.1	Context	55
5.2	Requirements	55
5.3	Solution	56
5.4	RFID Technology	57
5.5	Readers	58
5.5.1	Considerations	58
5.5.2	Market Offer	59
5.6	Antennas	61
5.7	Architectural Design	62
5.8	Software	64
5.8.1	Reader Interface Software	64
5.8.2	Software Platform	64
5.9	Our choice	65
5.9.1	Context	65
5.9.2	Implementation Design and Hardware	66
6	System Architecture and Development	71
6.1	Architecture	71
6.2	EPC Serialization Plan	73
6.3	Reader	74
6.3.1	Antenna and C1G2 Settings	75
6.3.2	Operation Configuration	78
6.4	F&C Middleware	80
6.5	Capture application	80
6.6	EPCIS repository and Adapter	81
6.7	Management application	82
7	Test and Evaluation	83
7.1	Tag orientation	83
7.2	Shelf RF Survey	85
7.3	Singulation stress test	86
7.4	Operational test	87
7.4.1	Problems	87
8	Conclusion and Future Work	89
8.1	Main achievements	90
8.2	Future Work	90

Referências	91
Appendix	101
EPC Schemes and Corresponding GS1 keys	101
Low Level Reader Protocol (LLRP) Messages	103
Production Docker Compose file	105
Octane SDK Reader Configuration Program	107
XML Reader Configuration Message Files	110
Reader Capabilities from <i>GET_READER_CAPABILITIES_RESPONSE</i> message	112
Impinj Readers Search Modes	116
Complex smart shelve solution ECSpec	117
Partial EPCIS Data Model in Golang	119

List of Figures

2.1	RFID system	7
2.2	Electromagnetic (EM) Field for antennas larger than the wavelength of the radiation it emits	9
2.3	Fields for antennas equal to, or shorter than, one-half wavelength of the radiation they emit	10
2.4	Components of a passive tag	10
2.5	Selection of passive UHF tag inlays for distinct applications from <i>Alien Technology, LLC</i> 2020 Product Family	11
2.6	United States of America (U.S.) Department of Energy prototype active tag with sensors for nuclear materials management working in 433.9MHz UHF ISO band	12
2.7	<i>CAEN RFID A927Z</i> semi-passive UHF logger tag for temperature monitoring of sensitive products during transportation and storage	13
2.8	Inductive coupled RFID system overview	14
2.9	Load modulation with subcarriers of a typical High Frequency (HF) RFID system	14
2.10	Passive backscatter RFID system	15
3.1	<i>EPCGlobal Architecture Framework</i> baseline example with EPC representations used at each level	25
3.2	Logical memory map of EPCGlobal Generation 2 (Gen2) UHF tags	28
3.3	Tag identifier (TID) Memory Bank of Monza R6-P Series used in this dissertation	30
3.4	<i>Pure Identity</i> and <i>Tag Uniform Resource Identifiers (URIs)</i> EPC representation	32
3.5	EPC in binary encoding representation	32
3.6	Relation and interoperability between Serialised Global Trade Item Number (SGTIN) and barcode's Global Trade Item Number (GTIN)	33
3.7	<i>RO_ACCESS_REPORT</i> message binary encoding	38
3.8	<i>TagReportData</i> parameter binary encoding	39
3.9	<i>EPCData</i> parameter binary encoding	39
3.10	<i>EPC-96</i> parameter binary encoding	39
3.11	Example of LLRP Application Flow	42
3.12	Example of Global Location Number (GLN) with extension (SGLN) in URI format	47
4.1	RFID-based electronic lockers from Keonn	52

4.2	CribMaster RFID inventory management solutions	53
4.3	Fabmatics RFID Rack design for wafer storage	53
5.3	Top view of two external antennas radiating a shelf at different angles	62
5.4	Arrangement with multiple compact antennas distributed in each shelf radiating upwards	63
5.5	Arrangement with two antennas per shelf, one in each side of opposing laterals radiating inwards	63
5.6	Quake Global Inc. EasyTAP751 middleware hardware solution	65
5.7	Leroy Merlin $176 \times 160 \times 60$ cmcm MDF and metal construction shelf	67
5.8	Keonn Advantenna-p14	67
5.9	Impinj Speedway R120 reader	68
5.10	HID 6H2E43 92×28 mm PET tag with 96 bit EPC	68
6.1	Overview of the solution architecture developed in this dissertation	72
6.2	Photograph of the Keonn Advantenna-p14 and Impinj Speedway R120 attached behind the bottom shelf	72
6.3	Deconstruction of a GS1-128 barcode from a Volluto coffee cardboard case for transport used in this dissertation as a test product	74
6.4	Illustration of company prefix Generation 1 Class 2 (C1G2) filtering parameter deduction	78
6.5	Functional block illustration with endpoints of the EPCIS-adapter developed in this dissertation	81
6.6	Web management application interface running on the OSX Safari browser	82
7.1	Tag orientation tested in this dissertation: horizontal, lateral and vertical, respectively . .	84
7.2	Received Signal Strength Indication (RSSI) reading results for the different considered tag orientations in dBm	84
7.3	Shelf RF survey showing the RSSI values within the 20×7 grid	85
7.4	RF survey obstructions points shown in conjunction with support metal bars and antenna placement	86
7.5	Non linear obstruction phenomenon illustrating miss readings caused by the removal of a tagged sleeve	87

List of Tables

2.1	Radio Frequency (RF) properties in different materials	17
3.1	Standards within the EPCglobal Architecture Framework	27
3.2	Protocol Control bits (PC) assignments from EPC UHF Gen2 Air Interface Protocol . .	29
3.3	Coding Table of SGTIN-96	34
3.4	SGTIN-96 binary encoding example of <code>urn:epc:tag:sgtin-96:1.76300544.07470.2 Tag</code> <code>URI</code>	35
3.5	EPC headers snippet	35
3.6	SGTIN Filter Value Table	36
3.7	SGTIN Partition Table	36
3.8	EPCIS Event Information Content example	48
5.1	Available EPC C1G2 reader chips and SMD modules on the market	59
5.2	EPC Class 1 Gen2 compatible readers well established on the market	60
5.3	A few UHF RFID compact antennas available on the market	61
1	EPC Schemes and Corresponding GS1 keys Part 1	101
2	EPC Schemes and Corresponding GS1 keys Part 2	102
3	LLRP Messages (except for responses) Part 1	103
4	LLRP Messages (except for responses) Part 2	104
5	Impinj Readers Search Modes	116

Glossary

AISpec	Antenna Inventory Spec	MDID	Mask Designer Identifier
ALE	Application Level Events	MIT	Massachusetts Institute of Technology
AOA	Angle of arrival	NFC	Near-field communication
API	Application Programming Interface	NID	Namespace Identifier
C1G2	Class 1 Generation 2	NSS	Namespace-specific String
C1G2	Class 1 Generation 2	ONS	Object Name Service
C1G2	Generation 1 Class 2	PC	Protocol Control bits
CBV	Core Business Vocabulary	PDOA	Phase Difference of Arrival
CRC	Cyclic Redundancy Check	PLC	Programmable Logic Controllers
CW	Continuous Wave	POS	Point of Sale
DCI	Discovery, Configuration, and Initialization	RF	Radio Frequency
DoD	United States Department of Defense	RFID	Radio Frequency Identification
DSFID	Data Storage Format Identifier	RM	Reader Management
EAN	European Article Number	R&D	Research and Development
ECReport	Event Cycle Report	ROSpec	Reader Operation Spec
ECSpec	Event Cycle Spec	RSSI	Received Signal Strength Indication
EDI	Electronic Data Interchange	SCM	Supply Chain Management
EIRP	Effective Isotropic Radiated Power	SGTIN	Serialised Global Trade Item Number
EM	Electromagnetic	SOAP	Simple Object Access Protocol
EMF	Electromagnetic Field	Spec	Specification
EMW	Electromagnetic Wave	SSCC	Serial Shipping Container Code
EPC	Electronic Product Code	SSCC	Serial Shipping Container Code
EPCIS	EPC Information Services	TCP	Transmission Control Protocol
F&C	Filter and Collection	TDS	Tag Data Standard
FPGA	Field-programmable Gate Array	TDT	Tag Data Translation
GDSN	Global Data Synchronisation Network	TID	Tag Identification
Gen2	Generation 2	TID	Tag identifier
GLN	Global Location Number	TMN	Tag Model Number
GPI	General Purpose Input	TOA	Time Difference of arrival
GTIN	Global Trade Item Number	UCC	Uniform Code Council
HF	High Frequency	UHF	Ultra High Frequency
HTTP	Hypertext Transfer Protocol	UMI	User Memory Indicator
IC	Integrated Circuit	URI	Uniform Resource Identifier
ID	Identifier	URN	Universal Resource Name
IFF	Identify Friend or Foe	U.S.	United States of America
IoT	Internet of Things	UUID	Universally Unique Identifier
IP	Internet Protocol	UWB	Ultra-wide band
IT	Information Technology	WORM	Write Once Read Many
JSON	JavaScript Object Notation	WSDL	Web Services Description Language
LF	Low Frequency	XML	Extensible Markup Language
LLRP	Low Level Reader Protocol	XPC	Extended Protocol Control
LRSpec	Logical Reader Spec	XSD	XML Schema Definition
		XTID	Extended Tag identifier

Introduction

1.1 BACKGROUND AND MOTIVATION

The new industrial revolution is centered around data. Yet, the true extension of this reformation might not be fully understood.

From manufacturing to retail, information and communication technologies disrupted the understanding of what could be improved through the supply chain ¹. To grasp the advantages of RFID, we have to understand its place with other technologies and how it can empower the relationship between manufacturing, transportation, logistics and retail.

The introduction of information and communication technologies in the manufacturing process, has been the foundation of Industry 4.0, which some people refer as the fourth industrial revolution [2]. It expanded the cyber-physical systems ² of the third industrial revolution and introduced Internet of Things (IoT), cloud and cognitive computing. The rise of wireless communications and the massification of data sensing in the manufacturing processes, allowed these technologies to enhance and optimize production processes, logistics operations and marketing strategies.

Adding IoT provided the network infrastructure for data transfer. Cloud computing enabled on-demand availability of Information Technology (IT) resources, fast deployment times and more efficient management strategies. Cognitive computing contributed with computer vision, signal processing and tools to analyze and process large amounts of data for operational optimizations and pattern recognition. These technologies support the modern digital end-to-end system of a business and its manufacturing processes.

UHF RFID improves the developments made in *Industry 4.0* by adding digital visibility of physical assets. But visibility inside a company is opaque to trading partners and vice versa. Visibility both inside and outside of the company is desirable. With EPC that is possible. Inside the company, physical objects can be digitalized, identified and wirelessly tracked. Outside, frontiers between company methods of operations and tools, can be abstracted in a

¹the sequence of processes involved in the production and distribution of a commodity [1]

²a system in which a mechanism is controlled or monitored by computer-based algorithms

common set of interfaces and standards that allows visibility of products outside company bounds and share of information between trading partners. This achieves an end-to-end integration of the complete commercialization process, where data from billions of physical items can be shared through the internet, enabling businesses and consumers to identify, locate and engage each item.

The future of RFID seems promising. In 2016, 96% of apparel retailers had plans to deploy tags on their products [3]. The United States Department of Defense (DoD) requires that all contractors must use UHF RFID identification since 2005 [4]. In 2014, Impinj, Intel, Google and Smartrac teamed up to form RAIN RFID, an organization whose mission is to promote the adoption of EPC UHF RFID. UHF RFID can greatly improve transport systems with cost reductions, smaller inventory, faster transportation and routing troubleshooting, lower insurance rates and greater efficiency [5].

Development and standardization of UHF RFID enables a symbiotic relation across the chain, connecting production, logistics, retail and client.

1.2 SCOPE

This dissertation explores the implementation of an UHF RFID smart shelf and software for retail inventory management, following EPCGlobal supply chain standards.

This smart shelf integrates the last stage of the supply chain and logistic industries, storing products in warehouses and stockrooms. It is the last life cycle of the product before selling to customers. The solution was designed to integrate Nespresso boutique stores in malls, with the objective of managing in real time the state of the warehouse product stock. These products would be tagged at the manufacturing facility and traced along the supply chain, ending up in these EPCGlobal-enabled shelves.

This work addresses basic RF notions, product design, implementation options, RFID air interface protocol tuning, EPCGlobal standards, interfaces and services configuration, using modern containerization technologies of cloud computing.

1.3 OUTLINE

The dissertation is divided in eight distinct chapters. The current introduces the motivation and background behind this work.

Chapter 2 presents basic knowledge required to understand RFID technologies and RF phenomenon. Starts by describing the components of RFID systems, addresses EM and Electromagnetic Waves (EMWs) theoretical concepts, it looks into tags and coupling techniques, readers, and ending with antenna notions.

Chapter 3 explores *EPCGlobal Architecture Framework* technologies required for the understanding of this dissertation. The chapter starts by contextualizing the standardization of the UHF RFID technologies, followed by a description of the framework activities. It continues by addressing and explaining all the EPCGlobal technologies used.

Chapter 4 introduces the state of the art of smart shelves. It goes through commercial available solutions, ending with the academic research in the area.

Chapter 5 contextualizes and presents the requirements of the solution. It elaborates on design, hardware and software options, discussing these approaches in regard to Research and Development (R&D) time and cost.

Chapter 6 describes the architecture, configurations and choices in respect to the smart shelf prototyped in this dissertation.

Chapter 7 concludes the practical work with the presentation of a set of tests designed to infer the smart shelf RF performance and ability to operate within the defined requirements.

Chapter 8 concludes this dissertation with a brief recapitulation of the work, supplementing it with a description of the main achievements and future work.

Basic principles of RFID

2.1 CONTEXTUALIZATION

The concept of identification using RF dates back to the late 1930s. By this time, the primitive biplanes made of wood and fabric used in World War I, had evolved to all-metal monoplanes. They were capable of carrying heavy quantities of explosives and travel at hundreds of kilometers per hour, making the conventional method of visual identification of incoming aircrafts obsolete. To counteract this issue, nations invested in research and development that culminated in the development of the microwave radar. By the time of the World War II, both fronts were using radar technologies to detect approaching planes. Still, the problem of identifying allied aircrafts from enemy ones, remained ¹. The German aircraft force, *Luftwaffe*, observed that as pilots rolled their planes, it would change the radio signal reflected back. With this ingeniously simple maneuver, they were capable of discriminate allied aircrafts, being roughly the first RFID passive application. [6]

It was soon later that Watson-Watt, under a British project, developed the first active RFID application to be used in Identify Friend or Foe (IFF) systems. An active RF transmitter was attached to British planes, which on receiving radar signals from base stations, broadcasted a signal identifying the aircraft as allied. [7]

The technology kept advancing through the 1950s and 1960s, mainly in the academic field, but with private companies starting to commercialize anti-theft systems based on 1-bit transponders ².

In the 1970s the first RFID patents were registered, namely, active tag with rewritable memory and a passive transponder for door lockers. It was during this time that the U.S. National Laboratory of Los Alamos was commissioned, by the Energy Department, to develop a tracking system for nuclear materials. The system revolved around transponders in trucks that would transmit information to readers at the gates of secure facilities. The Agricultural

¹The attack at Pearl Harbor in 1941 was possible due to a mistaken assignment of incoming Japanese aircraft to an unrelated U.S. bomber flight.

²a simple inductive RC resonant circuit that detects transponders in field by changes in the reader coil voltage [8]

Department also requested Los Alamos for an animal tracking system, which was designed in the UHF band with passive transponders, marking the beginning of the UHF RFID technology. These systems were also transposed by the same engineers to automated toll payment systems in the private industry [7], [9], [10].

In the 1980s, the development of the personal computer and technology promises, fueled an upsurge in investment, with private industries wagering in RFID. By the 1990s, deployments of RFID systems had grown significantly. The necessity of compatibility and interaction between proprietary systems rose, being established the first industry standards.

The 2000s followed the same maturation process with slow adoption in the late part of the decade. Despite the interest presented by retail giants like Wal-Mart, and investment by the DoD, compromises created by the RFID industry did not justify the commitment to the technology. The high cost for investment, technical performance difficulties, conflicting standards, security issues and privacy concerns made the investment unappealing [11]. Companies had to strangle R&D resources due to inexistent tools and complex implementations. Resources required to develop marketing and sales tools, which truly utilize the RFID infrastructure to increase revenue, had to be allocated to deploy RFID systems. Devise economic strategies for suppliers to transit to RFID also seemed to be a problem, since many ordinary companies don't have R&D resources at all to begin with [12]. Another big issue was the standardization of coding schemes in RF tags. The fight for dominance in the UHF RFID market led to multiple coding standards and protocols that made inter-operation among vendor and suppliers infeasible, if not impossible.

In the last decade, despite the advancements in the industry and adoption by big apparel retailers like Zara, Decathlon and Marks & Spencer [13], there are issues that inhibit wide-scale adoption of UHF RFID. These problems will be further discussed in chapter two of this dissertation.

2.2 RFID SYSTEM

RFID is an identification technology that uses radio waves or electro-magnetic fields to automatically identify physical objects and collect data about them.

Generally, RFID solutions start with a radio device called tag or transponder. The tag is attached to the object that needs to be identified. When such a object is presented in front of an antenna connected to a suitable RFID reader, the tag transmits data to the reader via the reader antenna. The reader then forwards the information through a communication channel to a software application running on a computer.

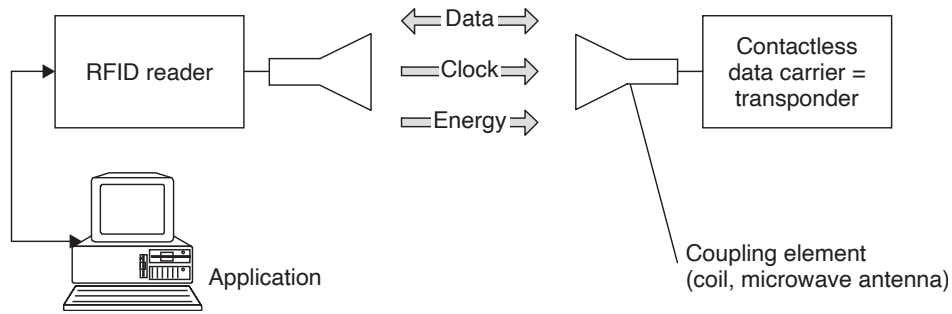

Figure 2.1: RFID system [14]

2.2.1 Components

An RFID system is a collection of components that implement an RFID solution [15]. Different references present different descriptions of RFID systems. Many specify where and which components should be implemented. The fact is, depending on the use case and requirements, these components can be implemented in different physical places or not implemented at all. With the current paradigm of IoT, machine learning and cloud computing, the discrimination of these components is even more difficult to establish. It is naive and intricate to predict what RFID system architecture will be like in the next few years.

The component description of RFID systems can be simplified to three physical blocks: *Tag* (or transponder) which is attached to the physical object to be identified, and is responsible for storing and transmitting appropriate data about the object; *Reader* and *Reader antenna* which interacts with transponders to read and write data; and *Back-end system* which encompasses all kinds of hardware and software components that are separated from the reader and support back-end infrastructures and business logic of a system.

From these, all components described in the literature can be specified and clearly added to one of the blocks. Other prevalent components used in RFID systems are:

Controller is an interface that allows an external entity to communicate with and control the reader's functions and devices connected to it.

Sensor, actuator and annunciator are optional components used for external input and output of the system.

Client Applications is a term for all hardware and software components that are separated from the reader device (e.g. middleware, point-of-sale terminals, etc.)

Communication infrastructure is the wired and/or wireless network, or serial connection infrastructure needed to connect the previously listed components

A run through the specificities of most of the components will be done in the following sections.

2.3 ELECTROMAGNETIC CONCEPTS

Before presenting the intrinsics around RFID system components, a basic expertise in EM concepts is paramount. Designing well performant systems requires a good understanding of electromagnetism fundamentals and its peculiarities.

Like other wireless technologies, RFID uses Electromagnetic Fields (EMFs) or EMWs as interface to transmit information back and forward between reader and transponder. Engineers have to grasp how EMFs and EMWs behave within distance to the reader antenna, how materials in tagged objects can interfere with RF signals, how unaccounted poor RF environments can compromise deployment of RFID systems, to say a few.

An EMF is the phenomenon produced by moving electric charges. It can be described through Maxwell's equations and mathematical abstracted as a combination of an electric field and a magnetic field that interact with each other and their surroundings.

The behavior of the fields changes as the distance from the source increases and are usually defined as two main regions: *near-field* and *far-field*. These regions separate RFID technologies in two very concrete operational groups. In reality, boundaries are not precisely defined, since the regions change their behavior in a progressive manner. The rough discrimination between regions in RFID exist to separate mutual coupling and radiation based technologies.

2.3.1 *Near-field*

Near-field manifests from the electric and magnetic fields near the charges and current that directly produced them. It is the region where phenomena like EM induction and electrostatic occur. This field can be further split in two regions: reactive *near-field* and radiative *near-field*.

Is in the reactive region that *near-field* RFID technologies are defined for. It is the closest to the transmitting antenna and is characterized by non-radiative behaviors. In this region, if the energy is not absorbed by a receiver, self-capacitance and self-inductive effects cause the antenna to store energy very near its surface. When electrons from a nearby conductor are placed in this region, reactive *near-field* energy is transferred to them, resulting in an energy drain on the transmitter by a change in the impedance viewed by the reader [14], [16].

In the radiative *near-field*, i.e. Fresnel region, the back-coupling of the fields becomes out of phase with the antenna signal, and thus cannot efficiently return inductive or capacitive energy from antenna currents or charges. In this region conductive objects, such as metal structures, can behave as antennas by inductively receiving and then “re-radiating” some of the energy [17].

The power of the field differers between field components with the distance (d) from the antenna. The magnetic field strength is proportional to $1/d^3$ and the electric to $1/d^2$. The *near-field* components are quite powerful but usually only suited for close range RFID technologies due to the rapid fall-off with the distance [16].

In the context of RFID technologies, only the reactive zone is considered when referring to the *near-field* region. The radiative zone is *ineffective* and rather unpredictable and usually not accounted referring to RFID.

2.3.2 *Far-field*

The *far-field* region is the region where the EM field behaves as “normal” radiating field, composed of EM waves that propagate outwards, i.e. electromagnetic radiation.

EM waves are created as result of uniform vibrations between an electric field and a magnetic field. In other words, EM waves are composed of oscillating magnetic and electric

fields. A change in one of the field components reflects an equal change of the other and one can not exist independently. These waves are detached from any feedback from the moving charges that produced it. Means that, after the waves leave the transmitter, they are completely independent of both transmitter and receiver, as opposed to the phenomena in the *near-field* region.

In this region the radiation amplitude decreases $1/d$ as the distance (d) from the reader antenna increases, being the suitable option for RFID technologies requiring high reading distances (e.g. UHF RFID).

2.3.3 Boundaries

The boundaries between these regions are characterized by locations where the activity of the associated field components are strongest. This does not mean that the other components aren't present, because they are. The transition between regions is progressive.

The *near* and *far fields* are roughly delimited by approximately one full wavelength of the RF wave emitted from a reader antenna. This can be more precisely defined taking in account the transmitting antenna characteristics.

For antennas whose size is comparable to one wavelength or bigger (used in UHF RFID), the *far-field* boundary is delimited by the Fraunhofer distance, radial from the antenna. The Fraunhofer distance is described by $2D^2/\lambda$, where D is the largest dimension of the radiator and λ the wavelength [16]. A representation of the borders between regions can be seen in figure 2.2.

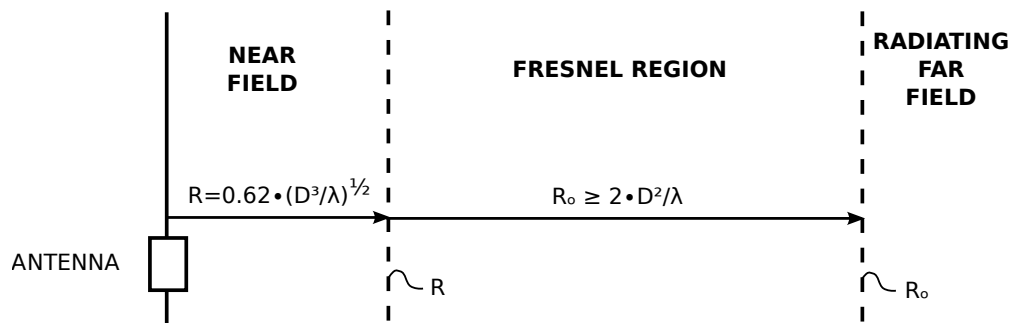

Figure 2.2: EM Field for antennas larger than the wavelength of the radiation it emits [18]

For small antennas, shorter than half of the wavelength of the emitting radiation, the *near-field* for RFID applications is usually upper limited by $\lambda/2\pi = 0.159\lambda$ [19]. Small antennas are used in Low Frequency (LF) and HF RFID technologies. For these technologies, which depend on the *near-field* for mutual coupling, the limit of the reactive region is the theoretical limit for the read distance. A delimitation of field regions for small antennas can be seen in figure 2.3.

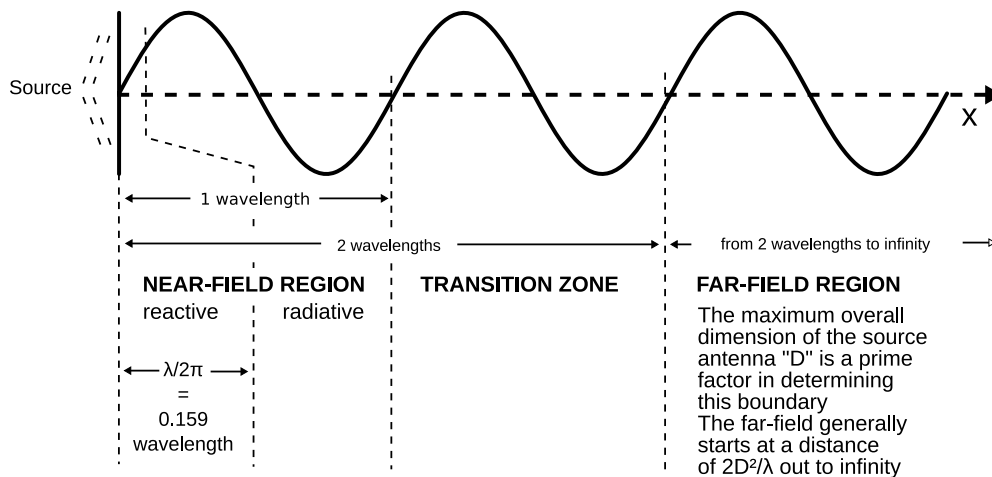

Figure 2.3: Fields for antennas equal to, or shorter than, one-half wavelength of the radiation they emit [20]

2.4 TAG

An RFID tag, also called transponder, is a device that can store and transmit data to a compatible reader in a contactless manner using radio waves or electro-magnetic fields.

Tag cost is the main factor in long term return on investment in RFID systems. It is one of the most important consideration when designing systems. After the initial investment in infrastructure, the expenses are mainly the acquisition of new tags. The reduction of cost per tag is the central focus of manufacturers and what allows the technology to be competitive in the world of Supply Chain Management (SCM).

At its simplest composition ³, a tag contains a microchip and an antenna, illustrated on figure 2.4. Depending on the technology the tag architecture and operation varies. Tags are characterized by their microchip, power source, memory characteristics and operating frequency. The following subsections will discussed these in detail.

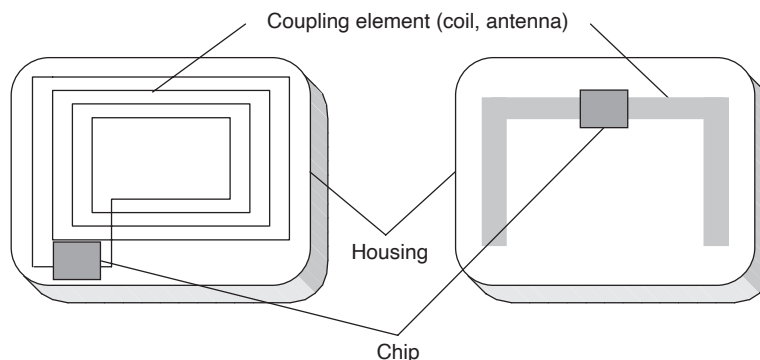

Figure 2.4: Components of a passive tag [14]

³an inductive RC resonant tag used in anti-theft systems is considered an RFID device, but is far from the requirements of modern RFID paradigms

2.4.1 Data Quantities

In the contextualization of RFID presented in section 2.1, we discussed the concept of identification and how it can be as simple as World War II IFF systems. An unidentified aircraft presents, upon radar lightening, its identification as being friend or foe. In computing language this can be abstracted as true or false, or 1 or 0. This kind of systems does not exchange more than a bit of information, the smallest unit of information, that can represent only two states. This type of transponders are called 1-bit transponders. Despite the limitations, they are still widely used in surveillance and anti-theft systems. Apparel retailers and other goods retailers have been using them for almost 6 decades and are still well established nowadays. This dissertation requires the identification of more than 2 types of objects, so the following content will jump over technical explanations of this type of transponder [14].

The type of transponder discussed through out this dissertation are n-bit transponders which use an electronic microchip as the data carrying device. These transponders can transfer data in different methods and are currently used in a variety of standards all over the globe.

The following sections of this chapter will approach concepts that are required to understand systems using n-bit tags, specifically UHF RFID. For a deeper analysis of other RFID systems refer to *The RFID Handbook by Klaus Finkenzeller* [14].

2.4.2 Power Supply

Passive tags

Passive tags are characterized for not having an on-board power source. Instead they use the power emitted from the reader antenna to energize themselves and transmit the stored data to the reader. As such, tag-to-reader communication is always started by a reader, since it needs to energize the tag.

A few examples of state of the art passive UHF tag inlays can be seen in figure 2.5. The simple constitution makes these tags robust, capable of withstanding corrosive chemicals such as acid and high temperatures ⁴. These are the type of tags that underwent most technology advancements in the last decade in order to meet performance, compatibility and cost expectations that make mass deployment feasible for companies.

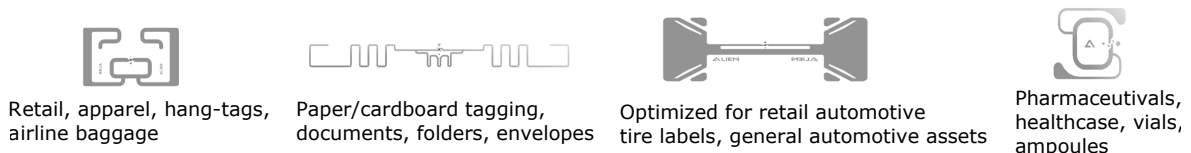

Figure 2.5: Selection of passive UHF tag inlays for distinct applications from *Alien Technology, LLC* 2020 Product Family [22]

⁴The new Impinj M730 and M750 UHF regular tags for item tagging sustains 206°C for 1 minute and can retain data at 125°C for 1 year [21, Tab. 18]

Active tags

Active tags have on-board power source and use it to transmit data to the reader. These type of tags do not need reader's emitted power for data transmission, therefore, in tag-to-reader communication, tags can either communicate first or be interrogated by a reader. Usually, active tags stay in a low-power state (i.e. sleep) in the absence of interrogation by the reader. When a reader wants to interact with a tag, issues a wake up command. The tag transits out the low-power state and resolves the interrogation. The RF environment generated by systems with these type of tags has generally much lower RF noise.

Since the presence of the reader is not necessary for data transmission, an active tag can broadcast its data, like a beacon, to its surrounding even in the absence of a reader. This is what is denominated as *transmitter*. Widely used for IoT applications as “wireless computers” to measure, process and transmit information about sensors, but out the scope of this dissertation.



(a) Tag mounted on Model 9975 drum

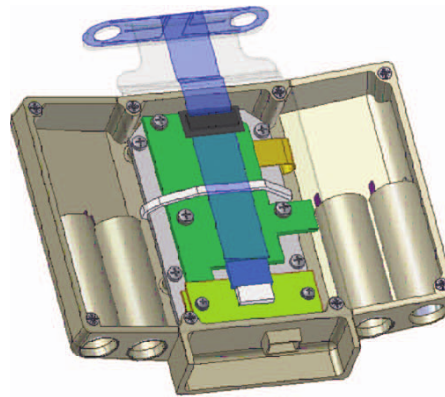

(b) Interior view of tag with metal back plate removed

Figure 2.6: U.S. Department of Energy prototype active tag with sensors for nuclear materials management working in 433.9MHz UHF ISO band [23]

Semi-passive tags

Semi-passive tags, also called *semi-active* or *battery assisted* tags, have on-board power source, but contrarily to active tags, it is only used for energizing the tag itself, thus, for transmitting its data, a semi-passive tag uses the reader's emitting power.

There are advantages of using these type of tags over passive ones. Semi-passive tags do not use the reader signal to excite itself, so it can be read from further distances compared to passive tags. Because no time is needed to energize a semi-passive tag, it can also be read much faster than a passive one, making them useful for applications where the tag is in the reading zone for a short period of time (e.g. tolls on highways). Finally, this type of tag might also offer better readability in RF-opaque and RF-absorbent materials.



Figure 2.7: CAEN RFID A927Z semi-passive UHF logger tag for temperature monitoring of sensitive products during transportation and storage [24]

2.4.3 Coupling

We discussed in section 2.3 how EMF behave throughout the space surrounding a transmitting antenna. Lets now understand how RFID technologies take advantage of Radio Frequency to establish a communication channel between reader and tag.

Coupling in RFID refers to the energy absorbed by a receiving antenna when a transmitting one is operating. It is a fundamental concept in RFID communications and affects several aspects of a system including range, frequency and cost. The coupling method and operating frequency are the defining parameters of technology categorization in RFID, presented in section 2.4.4 and used all over the world as a baseline to describe RFID systems.

There are three types of coupling techniques: inductive, capacitive and backscatter. This dissertation focuses on passive tag systems operating in the *remote-couple* (i.e. range from 1cm to 100cm) and *long-range* (i.e further than 100cm). Capacitive coupling is only exploited for data transmission in *close coupling systems* (i.e. range less than 1cm), therefore this type of coupling technique will not be discussed.

Inductive

Inductive-coupling systems, also known as magnetic-coupling, use the *near-field* magnetic component of the EMF to establish a mutual coupling between reader and tag.

The reader antenna coil generates a strong high frequency EM field. The variation of the magnetic flux excites the cross-section of the tag coil and induces a voltage. Considering the wavelength of the frequency range used (< 135 kHz: 2400m, 13.58MHz: 22.1m) is several times greater than the distance between reader antenna and the transponder, we can treat it just like a simple inductive coupling system, just like a transformer.

This voltage is rectified and supplied to the tag circuitry. The circuitry is actually designed to resonate at the transmission frequency of the reader. The resonance will generate high current in the reader, which produces the required field strength necessary for operation.

To transmit data from tag to reader, inductive systems use load modulation. The microchip changes de load on its coil in relation with the digital data to transmit. When a transponder, resonant at the transmission frequency of the reader, is placed in the reactive *near-field* region, through mutual coupling, energy is drawn by the transponder, being detected by the reader as a voltage drop in the internal resistance of the reader through supply of current to the

reader antenna. An illustration of an inductive coupled load modulation RFID system can be seen in figure 2.8.

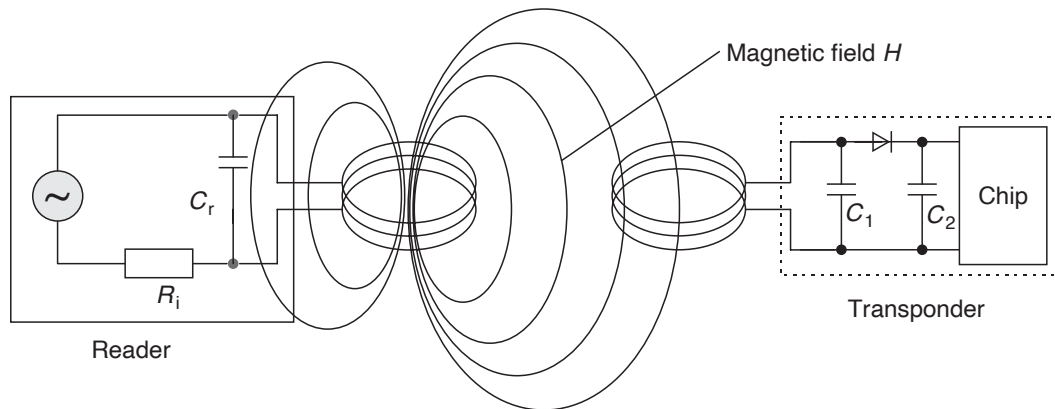

Figure 2.8: Inductive coupled RFID system overview [14]

This modulation method presents a fundamental problem. Due to weak coupling between antennas, there are voltage fluctuations at the antenna of the reader that are much higher than the fluctuations generated by the load modulation in the transceiver. This is a problem that usually appears in LF RFID systems. Detecting this slight voltages requires highly complicated circuitry which is undesirable. Modern systems (e.g. 13.58MHz HF RFID) use what is called: *load modulation with subcarrier*. It uses the side bands created around the operating frequency (f_T) for the transmission of data. Switching the load resistor at a high elementary frequency (f_s), generates two spectral lines at a distance of $\pm f_s$ which contains the modulated signal. An illustration of this can be seen in figure 2.9. The reader can demodulate and retrieve information that is carried in the sidebands of the two subcarrier sidebands, which are themselves created by the modulation of the subcarrier.

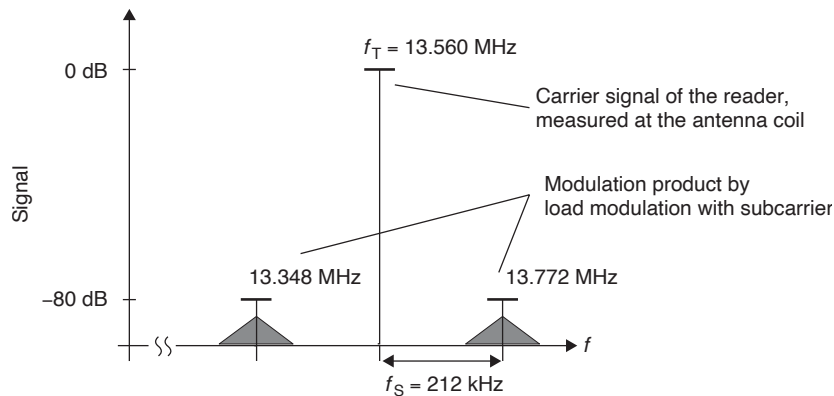

Figure 2.9: Load modulation with subcarriers of a typical HF RFID system [14]

Despite wide scale use and established global standardization, this type of coupling presents a few drawbacks. The reading distance is physically limited by the size of the reader antenna and the reactive *near-field* boundary discussed throughout section 2.3. The shrinkage of tag size is also technically challenging due to the power emissions regulations and the dependence with the variation of the magnetic flux through the cross-section of the tag antenna coil, that

excites the tag circuitry. The power consumption is also much higher than the next coupling technique we will look at, making it unsuitable for *long-range systems*.

Backscatter

Backscatter coupling harvests energy from the EMWs, transmitted by the reader antenna, to power the tag circuitry. It is mainly used in *long-range systems* since it is the primarily coupling technique capable of operate in the *far-field* region. To transmit data back to the reader, the tag *reflects* back some of the power as a modulated signal through what is called *modulated reflection cross-section*.

Modulated reflection cross-section operated by the same fundamental principles as the first RFID system invented and presented in section 2.1. It is known from radar technologies that EMWs are reflected by objects with dimensions greater than around half the wavelength of the wave. The efficiency with which an object reflects EMW is described by its *reflection cross-section*. Objects that are in resonance with the wave front that hits them, as is the case for antennas tuned to the appropriate frequency, have a particularly large *reflection cross-section*.

The modulation of the RF signal is created by changing the impedance viewed from the tag antenna, in similar manner to inductive coupling systems. Depicted in figure 2.10, a load resistor, connected in parallel with the antenna, is switched on and off in time with the data stream to be transmitted. The power reflected back changes in amplitude with the changing of impedance of the tag. The reflected signal is picked by the reader antenna, decoupled using a *directional coupler*, and finally demodulated [14], [25].

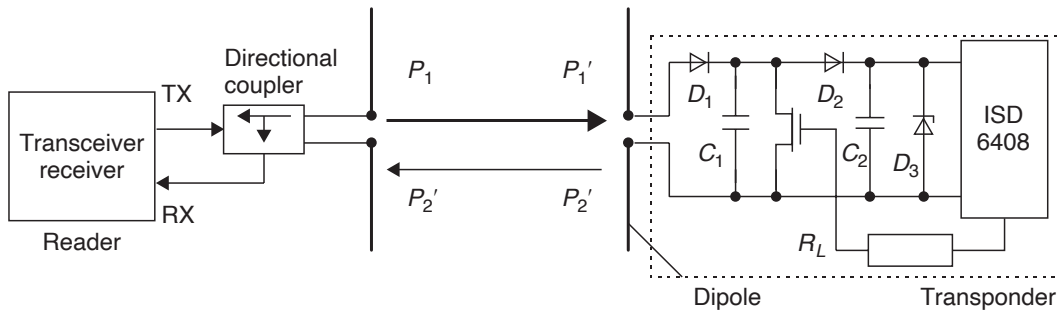

Figure 2.10: Passive backscatter RFID system [14]

2.4.4 RFID Technologies

When categorizing systems, the main aspect that defines RFID technologies is the operating frequency. In the previous sections we noticed a clear relation between operating frequency, through the wavelength, and system specifications like reading distance and data transfer speeds. So, it is no accident that this spontaneous categorization happened. RFID technologies tend to mature in a very clear path, being encompassed under use case specific standards with fixed operating frequencies carefully assigned by regulatory RF authorities in each country. It is indeed a useful classification method to summarize a set of specifications that usually need to be established a priori in RFID system design.

Being so, it is common in RFID slang to name systems by the frequency band they operate in. There are four preeminent frequency groups: LF, HF, UHF and Microwave. Ultra-wide band (UWB) RFID technologies will not be discussed, being in early phases of technological development. Each of the frequency groups presents characteristics inherent to their physical limitations that should be considered when choosing a technology.

Low Frequency (LF)

LF usually operates in the 125KHz to 134KHz frequency range, using passive tags through inductive coupling. Inherently, it has slow read speed and the reading range is limited to around 0.5m. Despite the drawbacks, they have good behavior in metals and liquids and are the most mature technology, probably having the largest installed based system. It is widely used in animal identification (ISO 11784/5 [26], [27], ISO 14223 [28]), access control, logistics and data collection [29], and automotive industry, in car ignition keys, to say a few.

High Frequency (HF)

HF operates mostly around the 13.54MHz frequency band. In same manner as LF, it uses inductive coupling. The higher operating frequency allows faster data read speeds while maintaining semi-decent behavior in metals and liquids. Widely used in smart cards [30], [31] for all kinds of applications and is the basis of Near-field communication (NFC) technology [32], [33]. NFC has been receiving a lot of attention. It is a global communication standard with a mature market (being roughly in any smartphone nowadays). This promoted big companies to invest in it, which began a wide scale manufacturing, resulting in the reduction of tag price (\$0.35 - \$10.00 per tag) and increase in system deployments.

Ultra High Frequency (UHF)

UHF operates in the band of 315MHz to 433MHz using active tags [34], and 860MHz to 956MHz using passive ones [35]. It is known for the promises it brings to SCM and logistics, being a cheap and affordable technology to wirelessly identify and track every item. It is mainly used in item tracking, but it can be adjusted for all kinds of applications. It uses backscatter coupling to transmit data between reader and tag. These frequencies present some drawbacks: poor behavior on liquid and metals is a big problem with passive tags; the allocation of the RF spectrum differs between countries being a huge problem for global deployments. This thematic will be further discussed throughout this dissertation.

Microwave

Microwave typically operates at 2.45GHz ⁵ [36], also called *Industry, Scientific, and Medical (ISM)* band, accepted globally. Uses backscatter coupling with passive, semi-passive and active tags. It performs very poorly in the presence of metals and liquids.

RF Materials Performance

RFID technologies, operating in the different frequencies, perform differently in the presence of distinct materials. Material can be: RF-lucent, in that they are translucent to

⁵5.8GHz ISO standard was withdrawn

EMWs; RF-opaque, where EMF can not penetrate the material; and RF-absorbent, in that it absorbs part of the EMF energy. Concise information on RF properties in different materials is presented in table 2.1.

Table 2.1: RF properties in different materials [15]

Material	LF	HF	UHF	Microwave
Clothing	RF-lucent	RF-lucent	RF-lucent	RF-lucent
Dry wood	RF-lucent	RF-lucent	RF-lucent	RF-absorbent
Graphite	RF-lucent	RF-lucent	RF-opaque	RF-opaque
Liquids (some types)	RF-lucent	RF-lucent	RF-absorbent	RF-absorbent
Metals	RF-lucent	RF-lucent	RF-opaque	RF-opaque
Motor oil	RF-lucent	RF-lucent	RF-lucent	RF-lucent
Paper products	RF-lucent	RF-lucent	RF-lucent	RF-lucent
Plastics (some types)	RF-lucent	RF-lucent	RF-lucent	RF-lucent
Shampoo	RF-lucent	RF-lucent	RF-absorbent	RF-absorbent
Water	RF-lucent	RF-lucent	RF-absorbent	RF-absorbent
Wet wood	RF-lucent	RF-lucent	RF-absorbent	RF-absorbent

There is a big market around single purpose tags for materials with poor RF performance. An informed decision must be made when selecting tags for systems dealing with materials portraying these characteristics.

2.5 READER

A reader is a device that can read from and write data to compatible RFID tags. It is responsible for sending and receiving RF signals to and from tags. If we strip down all the features modern readers offer, we can isolate three main components: RF front-end, processor, communication interface.

The RF front-end interfaces with the reader antenna. It is responsible for transmitting power and clock cycle via the antenna to tags in the reading zone, and demodulate RF signals received from tags to be further handled by the processor. Readers must adhere to RF modulation requirements and Effective Isotropic Radiated Power (EIRP) regulations if they want to be approved and commercialized. This fact promotes the implementation of the front-end by a dedicated transceiver microchip and complementary electronics, which is usually chosen. There are also efforts in implementing the RF front-end in Field-programmable Gate Arrays (FPGAs), which might change this paradigm in the next few years [37].

The processor is responsible for all logic necessary in the reader. It often comes with other complementary components like memory and dedicated Integrated Circuits (ICs) for specific tasks. Readers differ in architecture design between manufacturers, but the processor must at least implement the reader protocol to communicate with compatible tags. This includes decoding and error checking of the analog signals from the RF front-end, a controller interface to allow external entities to communicate with it, to transfer stored data, issue commands, accept commands and control the reader functions.

Communication interface is the component that provides communication instruction to a reader which allows external entities to interact with it. It usually comes inside microprocessors and microcontrollers ICs. It is usually seen in commercial readers as serial communication interface or ethernet.

Commercial readers come in a variety of types which are suited for different applications. The most common are stationary readers. Also called, *fixed* readers, they are what the name implies, used for making fixed reading zones. They also can be mounted on forklifts and inside of trucks. Other types are handheld readers, for a portable reading device and RFID printers which are used to print smart labels.

2.6 READER ANTENNA

A reader communicates with tags through its antenna. Antennas are responsible for converting guided Continuous Waves (CWs) in radiating EMW and vice-versa. It will only be covered radiating antenna theory for it is what is necessary to follow this dissertation.

In handheld readers, the antenna is generally integrated into the device. In stationary readers is most commonly found as a separate device attached to an antenna port of the reader by means of a cable. There are different groups of antenna designs: antennas composed of a wire, which encompass the dipole, monopole and loop antennas; constituted of an opening, like the horn and cavity backed slot antennas ; and printed circuit antennas like path antennas, commonly used in UHF RFID.

Evaluating antennas for RFID systems can be done through the parameters specified by the manufacturer, a few rules of thumb and engineering sensibility. At UHF we can control the direction of waves and other parameters, and thus improve the readability of tags.

2.6.1 Radiation pattern

An important parameter in antenna selection is the radiation pattern. Radiation pattern is the mathematical description or representation of the radiation properties of the antenna as a function of space coordinates. The radiation pattern illustrates the regions where the antenna's energy is most effective. In RFID is usually called the footprint of the antenna and determines the read zone. Manufacturers usually provide the radiation patterns for RFID antennas in the datasheet.

Different antenna designs radiate with different patterns. These radiation patterns are classified in three main classes: isotropic, directional and omnidirectional. For UHF RFID, directional antennas are really useful since it is possible to maximize directivity, that is, how well the radiation emitted is concentrated in a single direction. This increases reading distances and defines boundaries in reading zones. UHF RFID directional antennas are commonly patch antennas, also called *microstrip* or *planar antennas*. They consist of rectangular metal foil or a plate mounted on a substrate such as Teflon or FR-4 (i.e. woven fiberglass cloth with an epoxy resin binder).

Is also important, when designing RFID systems, to have notion of the deformations that occur in the radiation patterns. *Multi-path* phenomena - the reflection of EMW in RF-opaque

objects which causes waves to be scattered and arrive back at the reader in different paths and times - results in *phase* shifts leading to constructive and destructive interference. This creates protrusions and dead zones that will inevitably exist in most UHF RFID and microwave systems deployments.

2.6.2 Polarization

Antennas radiate EMW into surrounding space. Polarization is the direction of oscillation of the EMW and has a great importance in tag readability.

EMWs behave similarly to a wave of water. When a wave from a source, like a boat, reaches a buoy, the buoy moves mostly up and down. Analogously, EMW moves electrons in the plane perpendicular to the direction of propagation. The direction in which the field points, determines the polarization of the EMW. Unlike water waves, EMWs are not influenced by gravity, so the electric field can point in any direction in the plane perpendicular to the direction of propagation, and so have different polarizations [6].

The main types of polarization are known as linear and circular. Both types derive from the elliptical polarization, being linear and circular special cases of such.

Linear polarization

Linear polarized antenna emanate EMWs in a linear pattern, that is, emits EMW with only one field of energy.

These antennas have a narrower radiation beam with better directivity compared to circular polarized antennas. This results in longer reading distances and well-defined reading regions, which are essential to good RFID system design.

These advantages can sometimes fall short to the disadvantages. Linear antennas are sensitive to tag orientation with respect to its polarization direction. RFID tag antennas are usually dipoles constituted of narrow metal traces aligned in one direction. If the electric field is directed along the traces, it can push electrons back and forth inducing the voltage necessary to energize the tag IC. If the electric field is directed perpendicular to the trace axis, it moves electrons across the diameter of the trace, producing negligible current, insufficient to power the tag IC. Linear antennas are generally used in applications where tag orientation is fixed and predictable, or in conjunction with other complementary linear antennas.

Circular polarization

Circular polarized antennas solve, to certain degree, the orientation dependence problem with detriment of reading distance and a wider radiation beam. These antennas produce two energy fields that are equal in amplitude and magnitude, with a phase difference of 90° between them. This results in the electric field vector to be seen as helix like trace, a circular motion propagating through space.

Because the nature of circular polarized antennas, they are to a certain extent, unaffected by tag orientation. A circularly polarized EMW interacts with the linear antenna of a tag, tilted at any angle within the plane perpendicular to the axis of propagation, but in every case only half the transmitted power can be received. Good antenna design in tags can

modestly improve energy harvesting performance, e.g. incorporate two dipole antennas on the tag directed orthogonally to one another or physically larger bow-tie antenna designs.

These antennas are widely used in passive UHF RFID, specially in RF environment with high degree of RF reflectance, like due to presence of metals.

In the next chapter, I will introduce GS1 and their EPCGlobal Architecture Framework, used in SCM and logistics across the world and their close reallion with UHF RFID.

EPCglobal Architecture Framework

3.1 CONTEXT

Advances in UHF RFID gathered a lot of attention and investment in the beginning of the decade. The technology promised, for years, a disruption in the SCM which was never delivered.

Item level identification allows companies to capture product lifecycle information at remarkable levels of detail. RFID readers placed through out the supply chain can automatically capture information about tagged objects while they move from manufactured to consumer. An infrastructure that bridges the gap between the physical and the digital world, providing real-time information about current supply chain operations. Furthermore, the instant share of information between intervening companies increases supply chain visibility, resulting in reduced uncertainty in operational and tactical supply chain planning. Stock levels could be precisely controlled and shared with trading partners, which in turn reduces inventory costs and optimizes intra-company operations [38], [39].

It was an utopia ahead of its time. The technology was not mature enough, the return on investment was not appealing and cloud computing had just started to get traction.

This did not stop the conceptualization and development of architectures capable of delivering the promises we were hoping for. The architecture that stood relevant through out these uncertain times is the *EPCglobal Architecture Framework*. It was created and maintained by GS1, a non profit organization tasked with developing global standards for business communications. The organization has the experience, resources and influence to make this utopia a reality. The architecture shows on paper an appealing concept of a network capable of doing amazing thing for the SCM without restricting businesses IT architectures.

3.1.1 Standardization Efforts

Standardization of UHF RFID for item level tagging and supply chain, by organizations like GS1, provided a common language to identify, capture and share supply chain data, ensuring important information is accessible, accurate and easy to understand [40].

The first prominent adoption was by the U.S. DoD with a policy released on July 30th 2004. The policy stated that contracts issued for material delivery would require the use of UHF tags. The policy was later extended to all commodities and commodities pallets shipped to any DoD facility [4], [41].

In 2014, Impinj, Intel, Google and Smartrac, joined forces to create the RAIN RFID alliance after the ratification of GS1's UHF RFID Generation 2 version 2 standard in November of 2013. The alliance promotes the universal adoption of GS1's Gen2 UHF RFID technologies and cloud computing, where RFID-based data can be stored, managed and shared via the Internet [42]. The alliance fortified the adoption of GS1's standards and traced a common path for the industry to progress [43].

On October 11th 2018 the European Commission published their positive implementation of the upper band for European countries [44]. It extended the power levels to 2W in the lower band and added the requested global band from 915MHz to 921MHz with power levels up to 4W. This was the biggest effort by the European Commission to establish a global standardized frequency band for UHF RFID supply chain applications.

3.1.2 Current Problems

There are still RFID tags that do not conform with the international standards, often presenting proprietary formats and even encoding errors. These closed practices and struggle for market supremacy around UHF RFID creates a problematic situation that prevents conformity through the global logistics market.

Even in global standards, the adoption depends on the company and field of business. Usually one identification standard is already being used, and the migration cost for supporting multi-code integration can be high.

The information around global standards is also limited and hard to get through. It is divided in multiple specifications, identified with number notation and codification nomenclature. The ISO standards, in specific, are closed and have to be payed before even see its contents. These specifications are extensive and don't provide newcomers a good experience. Companies planning to implement UHF RFID systems following legitimate global standardization resort to consultants who have a deep knowledge on the standards complexity.

The closed mentality in the area slowed the industry progression. In comparison with the cloud and web industries, where experience and software is shared and open-sourced, UHF RFID tends to keep everything closed [45]. The existent freely available software is old, outdated and out of maintenance. Experience from real-world implementations is unavailable and it is not shared, making the industry prone to committing recurrent mistakes. This results in high investments in time and money on engineering resources that could be shared among industry leaders.

The positive implementation of the upper band frequency in Europe for global UHF RFID supply chain applications is also dependent on the acceptance by each European members. In particular, Germany and Netherlands are not accepting it [46]. The conflict with existing adopted bands in the countries makes a global homogeneous system a challenge that will need

time to be established.

3.1.3 GS1 and EPCglobal

GS1 is a nonprofit organization dedicated to the development and implementation of standards for global supply chain solutions. The institution mission is to manage the GS1 System of Standards, create open, global, multi-sector standards fostering good business practices.

GS1 established itself in 2005 from the European Article Number (EAN) International, Uniform Code Council (UCC) and other local organizations from the United States [47]. The organization took under its umbrella the former EAN-UCC roles subsuming their technologies. From those technologies, it is worth mentioning: the barcode identification system (from EAN), Extensible Markup Language (XML) standards, Electronic Data Interchange (EDI) transaction sets and supply chain solutions [15].

The new GS1 organization then adopted much more ambitious projects, developing global standards and services for business communication. From those efforts resulted the network for the synchronization of master data Global Data Synchronisation Network (GDSN), the EPC integration for RFID, traceability and the upstream integration of the consumer goods industry suppliers and *EPCglobal Network*.

For RFID Technology to become viable in practice, an infrastructure must exist for processing and communicating EPC data. In meeting the goal of creating a common infrastructure, Massachusetts Institute of Technology (MIT) announced Auto-ID Release 1.0 in October 2003. At the same time, MIT entered into an exclusive licensing agreement with GS1. In turn, GS1 established a new division called EPCglobal to implement Release 1.0 and to conduct further development based on industry input. This put forth an initial set of standards that formed the infrastructure for EPC data. Later, Auto-ID Release 1.0 became the starting-point for the *EPCglobal Network* and Architecture Framework [48].

3.2 OVERVIEW

EPCglobal Architecture Framework is a collection of interrelated hardware, software, and data standards that interoperate with shared network services [49]. These services are referred to as *EPCglobal Network*, a computer network used to share EPC data between trading partners. They are operated by GS1, its delegates and others to provide automatic, real-time identification and data sharing of items both within and outside of a company [15].

The framework defines information systems, interface standards and data models. This approach frees the market of IT systems to create custom business solutions. Manufacturing can have their custom business logic closed, and expose production state information to the clients through the *EPCglobal Network* with the EPCglobal interface standards.

The existence of these standards promote not only the global adoption of EPC, but also the exchange of information between business partners. Even though the network was designed primarily for RFID EPC data sharing, the network does not exclusively run on RFID data carriers. The Network can also be fed EPC data through data carriers like 1D and 2D

barcodes. The interoperability with the barcode was one of the most important considerations during the planning of the network [50].

3.2.1 Activities

The architecture defines three core activities, all of which have a group of standards and guidelines within the *EPCglobal Architecture Framework: Physical Object Exchange, Infrastructure for Data Capture and Data Sharing*, which I will be briefly brainstorm bellow. These activities are helpful in understanding the organization and scope of the framework but should not be interpreted as extremely rigid [49].

Physical Object Exchange

Identify individual physical objects - products, cases, loads, assets, return items, among others - so they can be tracked individually. Entities in the supply chain exchange physical objects identified with EPCs. Exchange operations can be such as shipping, receiving goods, and so on. For many End Users, the physical objects are trade goods, but this could not be the case. There are many other use cases, like library or asset management applications [51] that differ from the supply chain trade goods model, but still involve unique identification and tagging of objects. The architecture must be designed to ensure that when one *End User* delivers a physical object to another end user, the latter will be able to determine the EPC of the physical object and interpret it properly [49].

Infrastructure for Data Capture

Capture data about the movement of physical assets to create supply chain visibility. In order to gather EPC data, each *End User* carries out operations within its environment. Those can be: the creation of EPCs for new objects, follow the movements of objects by sensing their EPCs; and gather that information into recording systems within the organization [49].

Data Sharing

Exchange data with IT applications and trading partners, to turn visibility into information and action. *End Users* benefit from the *EPCglobal Architecture Framework* by sharing data with each other, increasing the visibility they have regarding movement of physical objects through the supply chain. The *EPCglobal Architecture Framework* standards provide a means for *End Users* to share data about EPCs within defined user groups or the general public.

3.2.2 Brief

The *EPCGlobal Architecture Framework* can be difficult to analyse and use. It is separated in multiple specifications and shows inconsistencies between documents, making the introduction to the framework fairly hard. Throughout this section I will introduce the baseline implementation of the *EPCGlobal Architecture*, introducing each intervening member and their role within the framework. This brief searches to provide a technical contextualization of the architecture for the next sections, where it will be thoroughly explained.

The *Architecture Framework* provides detailed specifications for three technologies developed by EPCGlobal: the Electronic Product Code (EPC), components of the *EPCGlobal Network™* and standards for RFID readers and tags.

The EPC is a unique ID used to identify an object. This EPC can be stored in different physical formats, including in RFID tags. These EPC enabled RFID tags can be attached to objects, and inspected throughout the supply chain by a network connected by services and readers. The simplest implementation of the *EPCGlobal Framework* can be structured like shown in figure 3.1. I will start on the bottom and go up in the architecture structure.

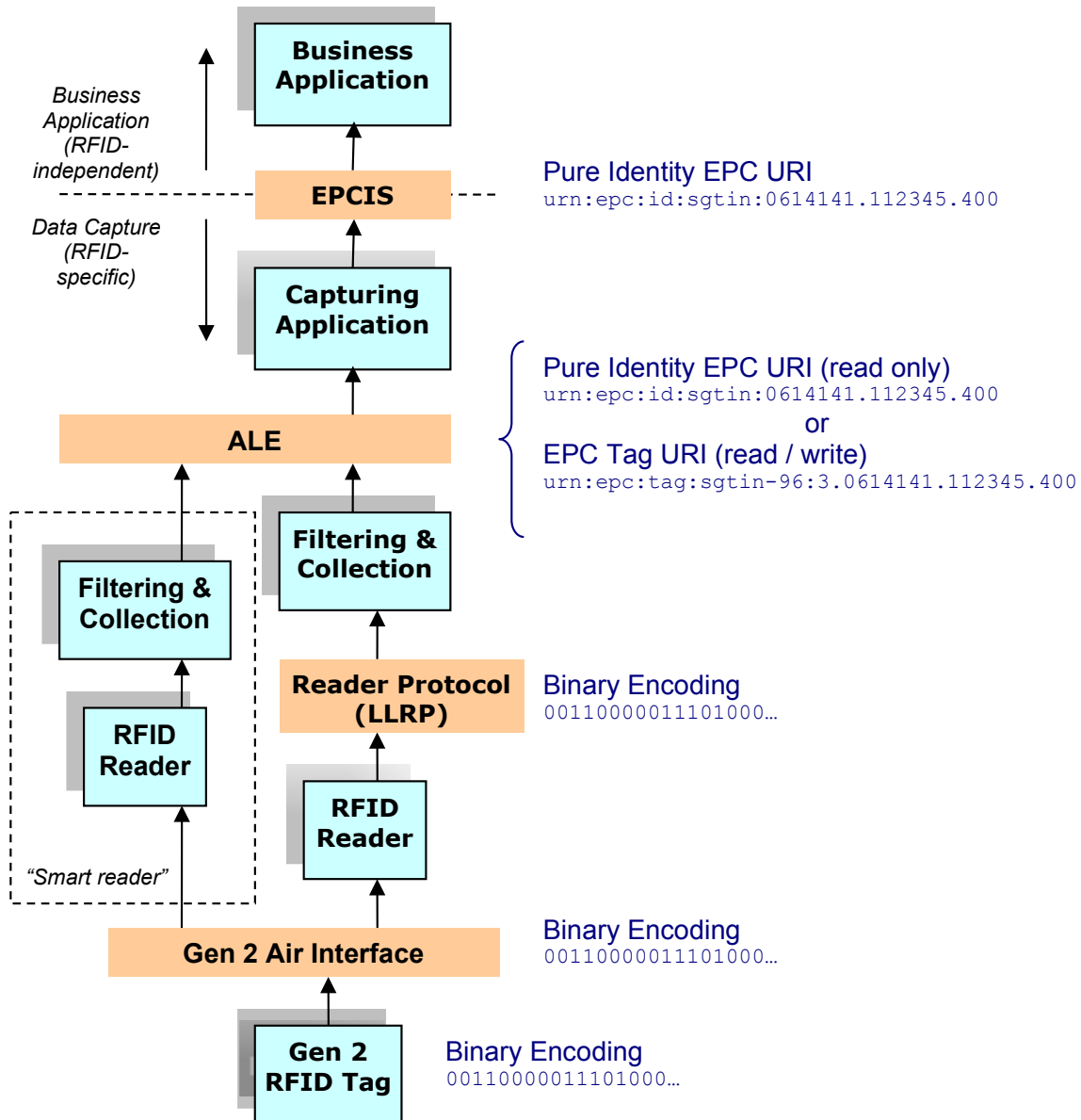

Figure 3.1: *EPCGlobal Architecture Framework* baseline example with EPC representations used at each level [52]

The Gen2 RFID Tag is the latest generation of the UHF tag standard design by EPCGlobal. Gen2 tags communicate with readers through the Gen2 Air Interface. The physical memory

map of Gen2 tags is standardized in the Tag Data Standard (TDS) [52], in conjunction with the binary encoding of EPCs. The RF communication link, signaling and commands between Gen2 tags and readers is defined in the Gen2 UHF RFID Standard [53].

Readers communicate with clients through the LLRP standard [54]. Gen2 readers can generate large amounts of network traffic and data, which needs to be processed. For that, *EPCGlobal Architecture Framework* defines Filter and Collection (F&C) middleware, to translate binary EPC into human readable format, and filter/aggregate data. F&C can be implemented in the same physical device as the reader, being called a “smart reader”.

Middlewares then send the processed data to Capture Applications, where EPC data is contextualized with business logic. Middlewares send this data through an ALE interface. The ALE interface allows Capture applications to register and subscribe to their interested EPC patterns and request strategies in a high-level declarative way. The interface is defined in its two documents [55] and [56].

Capture Applications send the contextualized data to Business Applications or data repositories. This data is sent following strict rules to ensure data is created and shared in a conformable and standardized way. The *EPCGlobal Architecture Framework* defines the EPCIS [57] and CBV [58] Standards, containing data models, vocabulary and communication interfaces required to create and share EPC related data with trading partners.

More standards and information paradigms exist in the *EPCGlobal Architecture Framework*, namely in the *EPCGlobal Network™* group of standards. The standards under the authority of *EPCGlobal Architecture Framework* can be seen in table 3.1. Relevant standards and congruous paradigms not in the practical scope of this dissertation: Reader Management (RM) standard to manage readers (not strongly adopted by the community); Discovery, Configuration, and Initialization (DCI); Tag Data Translation (TDT) for validation and translation of EPC identifiers; Object Name Service (ONS) a protocol to discover information about a product and related services from the EPC; and Global Data Synchronisation Network (GDSN), the network of interoperable data pools to share master data with their trading partners in a standard method.

Activity	Standard	Status
Object Exchange	<i>UHF Gen 2 Tag Air Interface</i>	Ratified Jul 2018 v2.1.0 [53]
	HF Class 1 Tag Air Interface	Ratified Sep 2011 v2.0.3 [59]
	<i>EPC Tag Data Standard (TDS)</i>	Ratified Nov 2019 v1.13 [52]
Data Capture Infrastructure	<i>Low Level Reader Protocol (LLRP)</i>	Ratified Oct 2010 v1.1 [54]
	Reader Management (RM)	Ratified May 2007 v1.0.1 [60]
	Discovery, Configuration, and Initialization (DCI) for Reader Operations	Ratified Jun 2009 v1.0 [61]
	<i>Tag Data Translation (TDT)</i>	Ratified Oct 2011 v.1.6 [62]
	<i>Application Level Events (TDS)</i>	Ratified March 2009 v1.1.1 [55], [56]
	<i>EPCIS Capture Interface</i>	EPCIS Ratified
	<i>EPCIS Data Standard</i>	EPCIS Ratified Sep 2016 v1.2 [63]
	<i>Core Business Vocabulary (CBV)</i>	CBV Ratified Oct 2017 v1.2.2 [58]
Data Sharing	<i>EPCIS Query Interface</i>	EPCIS Ratified Sep 2016 v1.2 [63]
	Pedigree Standard	Ratified Jan 2007 v1.0 [64]
	EPCglobal Certificate Profile	Ratified Jun 2010 v2.0 [65]
	Object Name Service (ONS)	Ratified Jan 2013 v2.0.1 [66]
	Global Data Synchronisation Network (GDSN)	Ratified Nov 2020 v3.1.14 [67]
	Lightweigh Verification Messaging Standard	Ratified Jul 2019 v1.1 [68]
	GS1 EDI [69]: XML standards	Ratified Nov 2019 v3.4.1 [70]
	Discovery Services	In Development

Table 3.1: Standards within the EPCglobal Architecture Framework

3.3 GENERATION 2 UHF TAG

Gen2 RFID tags are passive RFID tags that conform to the EPC Class-1 Generation-2 UHF RFID Standard for communications in the 860 MHz to 960 MHz frequency band, the ISO/IEC 18000-6 standard (Type C), or related standards currently under development.

The EPC Generation 2 Air Interface Protocol defines the physical and logical requirements for RFID readers and passive tags, operating in the UHF band, to communicate with each others [53]. In the context of this dissertation, we are particularly interested in Class 1 UHF tags. C1G2 tags are characterized for operating in the UHF or HF [59] bands, in Write Once Read Many (WORM) type RFID systems like SCM and logistics. They are cheap, robust, support cryptographic authentication for anti-counterfeiting, functions for traceability protection and most important, are conformable with the ISO/IEC 18000-6 Type C air protocol, conjugating the two most prominent standards in UHF conformable communication standard of operation.

It is important to address the C1G2 and ISO/IEC 18000-6 conformability. Despite the interrogation commands and logical memory map being the same, the standards differ in the data encoding. GS1 and ISO have different formats and encoding rules to represent Identifiers (IDs). Systems that want to support both encoding types have to implement

interoperability between them [71]. In this dissertation we focus on the *EPCGlobal Architecture Framework*. ISO encoding will not be covered.

3.3.1 Memory

Figure 3.2 depicts the logical memory layout in EPC Gen2 tags. It has four banks of non-volatile memory: *Reserved Memory*, *EPC Memory*, *TID Memory* and *User Memory*. Banks can be accessed by multiples of 16 bits words.

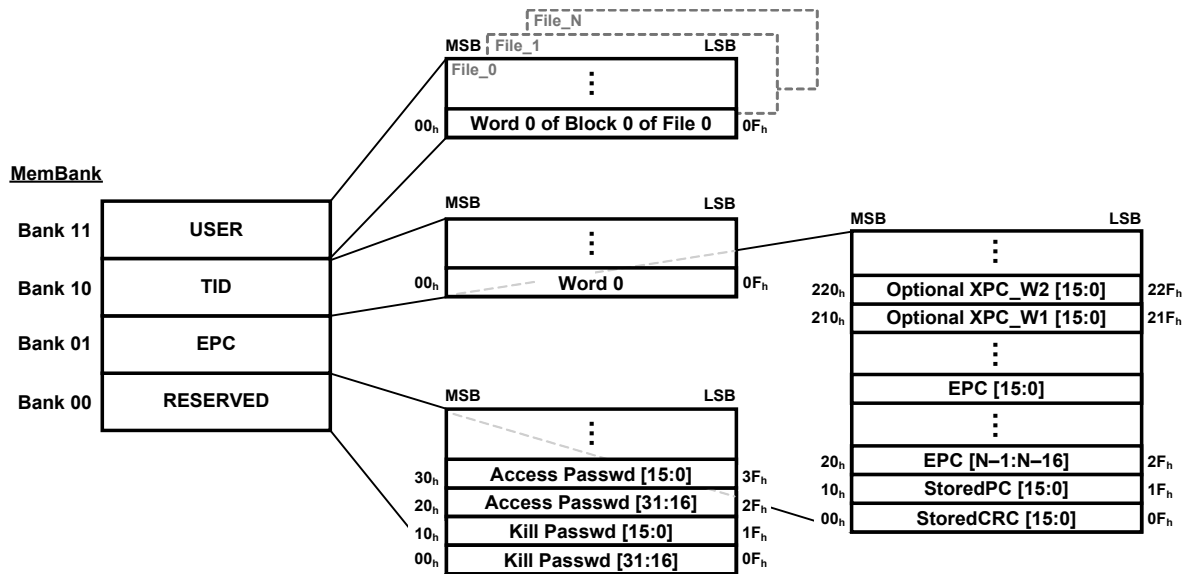

Figure 3.2: Logical memory map of EPCGlobal Gen2 UHF tags [53]

Reserved Memory

Reserved Memory (Bank 00) holds the Access and Kill passwords, if implemented by the manufacturer of the Tag. The *Kill password* is a 32-bit value used in the *Kill Command* to render a tag non-responsive thereafter. The *Kill Command* only executes if the password has been set to a value different from the default all-zero password. The *Access password* is a 32-bit value which allows a tag to transit in to the Secure state. In the Secure state all Access commands can be executed, including writing to locked blocks. The default password is all zeros and must be changed if access protection is desirable [53], [72].

EPC Memory

The EPC Memory (Bank 01) contains a 16-bit Cyclic Redundancy Check (CRC) for error correction, a 16-bit PC and an EPC.

EPC binary encoding will be further discussed in section 3.4.4, it is the ID in which the *EPCGlobal Framework* revolves around to identify every item in the world. The EPC is by design extensible, being that, depending on the application requirements, it can be between 96 bits and the maximum EPC size supported by the tag (some tags can have EPC memory up to 496 bits). Important to refer, tag cost rises with the amount of EPC bits. Companies planning on implementing EPC must devise a serialization plan where a estimate of serial

Application	MSB															LSB
	10 _h	11 _h	12 _h	13 _h	14 _h	15 _h	16 _h	17 _h	18 _h	19 _h	1A _h	1B _h	1C _h	1D _h	1E _h	
GS1 EPCglobal	L4	L3	L2	L1	L0	UM I	XI	T=0	RFU							
Non-GS1 EPCglobal	L4	L3	L2	L1	L0	UM I	XI	T=1	AFI as defined in ISO/IEC 15961							

Table 3.2: PC assignments from EPC UHF Gen2 Air Interface Protocol [53]

numbers and unique products is done. This will influence the requirements in EPC memory and consequently tag price. The encoding of EPC is not defined in the Gen2 air protocol standard, but in the *EPC Tag Data Standard* which will be further discussed with detail on section 3.4.

The standard also defines Extended Protocol Control (XPC) words, XPC_W1 and XPC_W2 respectively. These words are optional and usually not implemented by tag manufacturers. In fact, the tags used in this dissertation - with *Impinj's Monza* chips - are widely used in all kinds of tag applications around the globe, and don't implement XPC words. These words contain bit indicators for settings like hazardous materials and intractability to say a few.

The PC word contains metadata used to interpret the EPC. A more detailed representation of the PC can be seen in table 3.2. From 10_h – 14_h, 4 bits with the length of the EPC/ID in words, at 15_h a toggle bit called User Memory Indicator (UMI) which indicates if *User Bank 11* has any data in it, and at 16_h a toggle bit to indicate if the tag has extended PC. To distinguish a GS1 from an ISO standard ID, the most reasonable way is to look at bit 17_h, which contains a toggle bit to indicate whether the ID is GS1 or non-GS1 family. From bit 18_h to 1F_h is reserved for future use under the *EPCGlobal* specification. Under some circumstances GS1 EPCglobal may permit other standard body or organization to use one or more of these RFU values for standardization purposes. Also to note, on ISO 18000-6, these bits are used for ID's supplementary meta data called Application Family Identifier.

TID Memory

TID Memory (Bank 10) holds chip manufactured information and tag capability indicators. This memory bank is permalocked at the time of manufacture, in that it can not be changed.

The TID Memory bank contains two fields - Mask Designer Identifier (MDID) and Tag Model Number (TMN) - which are commonly associated together and called TID. MDID encodes the tag chip manufacturer ID which is assigned by GS1 as a unique identifier. The TMN is attributed by the manufacturer of the chip and describes the chip identification number.

The TDS, where the encoding of TID is specified, is often referred as *Short Tag Identification*, because the TID can be extended.

The TID extension is called Extended Tag identifier (XTID) and is intended to provide more information about the capabilities of tags. It adds support for serialization and information about key features implemented by the tag [52]. Serialization is unique number generated

MONZA 6 TID MEMORY BANK																
Word	0	1	2	3	4	5	6	7	8	9	A	B	C	D	E	F
50 _h -5F _h	0	0	0	0	1	0	0	0	1	1	0	1	1	1	1	1
40 _h -4F _h	1	1	0	0	1	1	0	0	1	1	1	0	1	0	1	1
30 _h -3F _h	0	0	0	1	0	0	0	0	1	0	0	0	1	0	0	1
20 _h -2F _h	0	0	1	0	0	0	0	0	0	0	0	0	0	0	0	0
10 _h -1F _h	0	0	0	1	0	0	0	1	0	1	1	1	0	0	0	0
00 _h -0F _h	1	1	1	0	0	0	1	0	1	0	0	0	0	0	0	0

MEMORY MAP LEGEND				
Segment	Location	Bits	Binary	Value
ISO / IEC 15963 Class Identifier	00 _h -07 _h	8	11100010	GS1 EPCglobal Class 1 Gen 2
XTID Indicator (X bit)	08 _h	1	1	Indicates the presence of an extended TID (XTID)
Security Indicator (S bit)	09 _h	1	0	Does not implement <i>Authenticate</i> or <i>Challenge</i> commands
File Indicator (F bit)	0A _h	1	0	Does not implement the <i>FileOpen</i> command
Mask Designer Identifier (MDID)	0B _h -13 _h	9*	000000001	Impinj
Tag Model Number (TMN)	14 _h -1F _h	12	000101110000	Tag model number (Monza R6-P)
EPC Tag Data Standard Header	20 _h -2F _h	16	0010000000000000	Supports extended TID (XTID) – 48-bit SN
Wafer Mask Revision	30 _h -32 _h	3	000	Indicates the Mask Revision for the tag
Integra™ TID Parity	33 _h	1	1	Bit is set to guarantee bits 30:5F have even parity
Reserved for Future Use	50 _h -52 _h	3	000	
Monza Series ID	53 _h -54 _h	2	01	Supports Series 0 – Series 3
Monza Series Cycle Counter	34 _h	1	0	Series rollover indicator
Serial Number		38	0001101111111001100 1110101100010001001	30037989513 (decimal)

*The GS1 currently defines the MDID as the 9 bit value from 0B_h to 13_h in the Tag Data Standard (TDS). A previous TDS definition included the X, S and F bits in the MDID. For applications using a 12-bit MDID, the value would be 100000000001_b or 801_h.

Figure 3.3: TID Memory Bank of Monza R6-P Series used in this dissertation [73]

by the tag manufacturer and can be used to uniquely identify one tag from another. This identifies the tag itself, rather than item it is applied to. XTID implementations are common among tag manufactures. So common in fact, people started referring to the MDID, TMN and serialization combination as *TID number*. The XTID is specially useful in cases where the EPC is not serialized or invalid. An example of a TID memory bank with XTID can be seen in figure 3.3.

User Memory

The User Memory Bank provides a variable size memory to store additional data related to the tagged object. It is frequently used to save information like temperature, maintenance logs, expiration dates and other type of data. The bank implementation is optional and must be indicated in the UMI bit in the PC Word.

To ensure compatibility with other protocols, the first eight bits of the bank shall contain a Data Storage Format Identifier (DSFID) as specified in ISO15962 [74]. This dissertation does not make use of the User Memory Bank, whereby it will not be covered. For further reference, GS1 presents a solution for encoding SCM data in the User Memory Bank in the TDS [52].

The access to the bank is made in blocks, through the Gen2 Air Protocol. The arrangement of the data in the Bank is important, as it can impact reading speeds. GS1 provides a user memory encoder, a software which converts application data, into suitable encoded data ready to be stored in the User Memory Bank of Gen2 RFID tags [75].

3.4 ELECTRONIC PRODUCT CODE (EPC)

EPC is a universal identifier used to identify every physical object anywhere in the world. Differently from common Universally Unique Identifier (UUID) identifiers, EPC has a set of collective terms for the identification code, standardized by GS1 [76]. These terms convey context about the physical object in the encoding of the EPC itself.

3.4.1 EPC in EPCGlobal Architecture Framework

EPCs are presented throughout the EPCGlobal Framework in various levels of abstraction. From low-level binary encoded, in Gen2 RFID tags, to text based URIs in business level applications. The Framework presents seven representations¹ for a single EPC. In general, only three are primarily used: *Pure Identity*, *Tag URI* and *Binary Encoding*. Referring back to figure 3.1, we observe that the three representations are used in different contexts throughout the framework.

The *Pure Identity EPC URI* format is, as the name suggests, represented in Uniform Resource Identifier (URI) format. GS1 uses the Universal Resource Name (URN) scheme with the `epc` Namespace Identifier (NID) registered for the EPCglobal's EPC and related standards [77]. It is the most platform agnostic representation of an EPC, offering human readability and compatibility between heterogeneous systems.

For components like middlewares, requiring more information about the EPC memory bank of Gen2 RFID tags, the TDS provides a *Tag URI* scheme. This representation maintains the URI representation, changing the Namespace-specific String (NSS) from `id` to `tag`, and adding *control information* used to guide the process of data capture of RFID tags. This scheme preserves information regarding the EPC Memory Bank in the URN namespaces that are usually disregarded in business applications but necessary in middleware operations. In

¹binary, tag-encoding URI, pure-identity URI, legacy, legacy AI, element string and ONS hostname

3.4.3 SGTIN

In the scope of this dissertation, the SGTIN scheme is the most important encoding scheme to look at. The SGTIN encodes a GTIN plus a unique product or serial number.



Figure 3.6: Relation and interoperability between SGTIN and barcode's GTIN

The GTIN is used by companies to identify trade items [79], [80]. GS1 defines trade items as products or services that are priced, ordered or invoiced at any point in the supply chain. GTIN can be used to identify types of products at any packaging level (e.g., consumer unit, inner pack, case, pallet ²).

There are four GTIN formats: GTIN-8, GTIN-12, GTIN-13 and GTIN-14. In RFID applications and IT applications, it is used the generalized 14-digit GTIN format. Gen2 RFID SGTIN encoding scheme is specified for GTIN-14. Other GTIN formats are mainly used in barcodes in point-of-sale applications: in the U.S. is commonly used a GTIN-12 with UPC barcodes for single products and GTIN-14 with ITF-14 barcodes for product grouping. In contrast, in the rest of the world is commonly used GTIN-8 with EAN-8 barcodes for single products and GTIN-13 with EAN-13 for single products packaging configurations [82], [83].

A GTIN is composed of three fields: *Company Prefix*, *Item Reference* and check digit. All these fields are encoded in the same manner in the different N-digit GTIN formats. A GTIN-13 can be converted in a GTIN-14 by adding a leading zero, and other GTINs formats follow the same logic.

GS1 *Company Prefix* is an identifier licensed by GS1 to identify a company globally. Nowadays, the registration of such is essential to companies wishing to sell products in big retail stores and digital marketplaces like Ebay and Amazon [84]). A *Company Prefix* does not uniquely identify a manufacturer. Companies can register and own more than one *Company Prefix* [49], and in certain circumstances *Company Prefixes* can change. When licensing a *Company Prefix*, there is an assessment and plan of unique product items a company shall produce. Depending on that, GS1 attributes a prefix with a length adjusted to company requirements. Companies requiring high quantities of unique item are given a shorter Company Prefix, accommodating more digits for item identification. Also worth mentioning, the attribution of *Company Prefixes* is made by one of the GS1 branches. Each

²even if a GTIN can be used to identify pallets, the use of Serial Shipping Container Code (SSCC) is preferable [81]

branch has a prefix which uses to assign *Company Prefixes* (e.g. GS1 Portugal has 560, GS1 Schweiz, Suisse and Svizzera have 760-769) [85].

Item References are assigned by the managing entity of the product. The item reference must be concatenated with the *Company Prefix* to calculate the Check Digit, forming a GTIN. From a GTIN, an SGTIN can be commissioned³, allowing to uniquely identify a product within its product grouping. Important to clarify, when a GTIN is stored in RFID tags, as in SGTIN coding schemes, the Check Digit has no purpose, so it is dropped. The Check Digit exists for error checking in barcodes. When converting barcode GTIN to EPC SGTIN encoding scheme, the Check digit must be dropped.

3.4.4 Binary Encoding

Lets now understand how EPCs are stored in Gen2 RFID tags. We will focus on SGTIN encoding scheme, but the encoding method is analogous to other encoding schemes.

The binary encoding of an EPC consists of a fixed length header followed by a series of fields inherent to the encoding scheme like showed on SGTIN-96 Coding table 3.3. For instance, lets take the *Tag URI* `urn:epc:tag:sgtin-96:1.76300544.07470.2` has example. This *Tag URI* presents a SGTIN-96 encoding scheme, *Filter value* of “1”, *Company Prefix* “76300544”, *Item Reference* “7470” and serial “2”.

Following table 3.4, showing the *Tag URI* encoding, we first need to address the EPC header value. A snippet of the EPC header values can be seen in table 3.5. We observe that an SGTIN with 96-bit coding scheme encodes a 8-bit header with binary value of “00110000”.

Next, we need to encode the additional *information* included in the EPC Memory Bank: *Filter* and *Partition*.

³“Commissioning” is the technical term used when creating new EPCs for objects

Scheme	SGTIN-96					
URI Template	urn:epc:tag:sgtin-96:F.C.I.S					
Total Bits	96					
Logical Segment	EPC Header	Filter	Partition	GS1 Company Prefix (*)	Indicator (**)/ Item Reference	Serial
Logical Segment Bit Count	8	3	3	20-40	24-4	38
Coding Segment	EPC Header	Filter	GTIN			Serial
URI portion		<i>F</i>	<i>C.I</i>			<i>S</i>
Coding Segment Bit Count	8	3	47			38
Bit Position	$b_{95}b_{94}...b_{88}$	$b_{87}b_{86}b_{85}$	$b_{84}b_{83}...b_{38}$			$b_{37}b_{36}...b_0$
Coding Method	00110000	Integer	Partition			Integer

Table 3.3: Coding Table of SGTIN-96 [52]

Field	Value (dec)	Value (bin)	Length (bits)	Notes
EPC Header	48	00110000	8	SGTIN-96 encoding
Filter Value	1	001	3	Point of Sale (POS) item
Partition Value	4	100	3	Company Prefix has 8 digits
Company Prefix	76300544	1001000110001000 001000000000	27	
Item Reference	7470	00001110100101110	17	Length depends on the partition MSB zero fill
Serial	2	0000000000000000 00000000000000000010	38	Serial is of fixed length. Can be extended with bigger EPC Memory Bank

Table 3.4: SGTIN-96 binary encoding example of `urn:epc:tag:sgtin-96:1.76300544.07470.2` Tag URI retrieved from the Platform developed in this dissertation

Header Value (binary)	Header Value (hexadecimal)	Encoding Length (bits)	Coding Scheme
...			
0010 1100	2C	96	GDTI-96
0010 1101	2D	96	GSRN-96
0010 1110	2E	96	GSRNP
0010 1111	2F	96	USDoD-96
0011 0000	30	96	SGTIN-96
0011 0001	31	96	SSCC-96
0011 0010	32	96	SGLN-96
0011 0011	33	96	GRAI-96
0011 0100	34	96	GIAI-96
0011 0101	35	96	GID-96
0011 0110	36	198	SGTIN-198
0011 0111	37	170	GRAI-170
0011 1000	38	202	GIAI-202
0011 1001	39	195	SGLN-195
0011 1010	3A	113	GDTI-113 (DEPRECATED as of TDS 1.9)
0011 1011	3B	Variable	ADI-var
0011 1100	3C	96	CPI-96
0011 1101	3D	Variable	CPI-var
0011 1110	3E	174	GDTI-174
0011 1111	3F	96	SGCN-96
0100 0000	40	110	ITIP-110
0100 0001	41	212	ITIP-212
...			

Table 3.5: EPC headers snippet adapted from TDS [52]

Type	Filter Value	Binary Value
All Others	0	000
Point of Sale (POS) Trade Item	1	001
Full Case for Transport	2	010
Reserved	3	011
Inner Pack Trade Item Grouping for Handling	4	100
Reserved	5	101
Unit Load	6	110
Unit inside Trade Item or component inside a product not intended for individual sale	7	111

Table 3.6: SGTIN Filter Value Table [52]

Partition Value (<i>P</i>)	GS1 Company Prefix		Indicator/Pad Digit and Item Reference	
	Bits (<i>M</i>)	Digits (<i>L</i>)	Bits (<i>N</i>)	Digits
0	40	12	4	1
1	37	11	7	2
2	34	10	10	3
3	30	9	14	4
4	27	8	17	5
5	24	7	20	6
6	20	6	24	7

Table 3.7: SGTIN Partition Table [52]

The *Filter* encodes the packing level. An EPC SGTIN can be used to identify different levels of item packaging sharing the same GTIN. Differently from barcodes, which only encode the GTIN, an EPC with *Filter* field allows a coherent GTIN across all item packages. The *Filter* value allows RFID readers to select or deselect tags in the *EPC UHF Gen2 Air Interface Protocol* corresponding to certain filter levels. This makes it easier to read desired tags in an environment where there may be other tags present (e.g. logistics companies only wanting to read and track Unit Loads like pallets). Referencing table 3.6, with a filter value of “1”, it encodes a POS Trade Item with binary encoding of “001”.

The *Partition* value encodes a pair of variable-length numeric fields referent to the *Company Prefix* and *Item Reference* memory partition. Previously we mentioned that *Company Prefixes* can vary in length depending on company requirements for unique *Item References*. In barcodes the *Company Prefix* and *Item Reference* are encoded together in a GTIN value. In Gen2 tags, although there is fixed size memory shared between *Company Prefix* and *Item Reference*, there is also the *Partition* value, which specifies the distribution of that partition between booth fields. In the case of the *Tag URI* example, *Company prefix* has 27 bits (8 digits) and *Item reference* has 17 bits (5 digits). Referring to table 3.7 showing the pair of variable-lengths, the *Partition Value* is “4” encoded has “100”.

The *Company Prefix*, *Item Reference* and *serial* are encoded converting from decimal to

binary and add leading zeros to fill all bits in each Logical Segment.

3.5 LOW LEVEL READER PROTOCOL (LLRP)

The Low Level Reader Protocol (LLRP) is specification for the network interface between RFID Readers and Client applications [86]. LLRP is not exclusive to the Gen2 Air Protocol. It was designed to support multiple RFID air protocols, including future versions of Gen2 Air Protocol.

3.5.1 Design Requirements

In some RFID systems, there is a requirement for explicitly tune RFID air protocols and the ability to control Readers that implement RFID air protocol communications [54]. LLRP provides tuning features and commands for that purpose.

Devices intended to operate and communicate with RFID Readers can vary from software applications, to middleware on local hardware, Programmable Logic Controllers (PLCs) and even cloud services. LLRP is “simple” enough to be implemented in all kinds of computer architectures.

LLRP was design without requiring real-time interaction between the application software and Reader, and but with time-critical tasks at heart. The Reader application software passes operational rules to the Reader in non-real time. The Reader then triggers and runs those operation rules to achieve time-critical requirements. The triggers can come from the applications directly, from timers, General Purpose Input (GPI) hardware, or any other trigger defined by the Reader. This declarative operation method allows Readers to achieve peak performance without constraints caused by network or host latency.

3.5.2 Connection Details

LLRP is a binary protocol which runs over the TCP/IP internet transport protocols. It is an asymmetric protocol where the LLRP client sends commands to the Reader.

The protocol supports both reader and client initiated connections. By default, LLRP clients connect to TCP port 5084. In reader initiated connections, the Reader will actively try to establish a connection with the host application. LLRP does not specify the behavior delivering data when a connection is broken. The reader used in this dissertation will continue to collect tag data and optionally deliver upon resumption of the connection.

Readers only allow one LLRP connection at any time. The Transmission Control Protocol (TCP) connection between reader and client stays open until the client closes it or connection drops.

3.5.3 Operation

The primary function of the LLRP interface is to allow a client to finely tune the Gen2 Tag Air Standard parameters, and command the reader to perform an inventory and otherwise access tags for read, write, lock, and kill.

0										1										2										3	
0	1	2	3	4	5	6	7	8	9	0	1	2	3	4	5	6	7	8	9	0	1	2	3	4	5	6	7	8	9	0	1
Rsvd		Ver		Message Type = 61												Message Length [31:16]															
Message Length [15:0]															Message ID[31:16]																
Message ID[15:0]																															
TagReportData Parameter (0-n)																															
RFSurveyReportReportData Parameter (0-n)																															
Custom Parameter (0-n)																															

Figure 3.7: *RO_ACCESS_REPORT* message binary encoding [54]. This message is sent by the Reader and contains inventory and access operations results

To meet these requirements, LLRP defines Specs, containing descriptions of “what, how and when” the Reader should perform certain operations. Specs are only run when triggered. The trigger ranges from boundary trigger information defined in the Spec itself, GPIs, or by immediate triggers from applications for a more imperative behavior. Specs are sent inside of messages, which are the unit of communication between client and Reader. LLRP contains forty basic messages which range from commands, responses, events and a *CUSTOM_MESSAGE* for vender extensions. A list and description of every message can be found in Appendix 8.2.

In figure 3.7 we observe an example of binary encoding of the *RO_ACCESS_REPORT* message. Inside the message there is a Spec, and inside data is sent as *parameters* and *fields*. *Fields* are individual data elements with a known basic format. *Parameters* are named data elements that contain other parameters and/or fields, much like structures in programming languages. Inside the *RO_ACCESS_REPORT* message, in figure 3.7, it can be observed the memory allocated for a list of a parameter called *TagReportData*. *TagReportData* is then encoded following figure 3.8, which inside encodes an *EPCData* or *EPC-96* parameter, where the binary encoded EPC is allocated. When constructing LLRP messages, parameters can be optional, but field must be presented and within their valid range. Some tooling software provides user friendly features like inferring Reader capabilities and default values for unspecified fields.

0										1										2													3
0	1	2	3	4	5	6	7	8	9	0	1	2	3	4	5	6	7	8	9	0	1	2	3	4	5	6	7	8	9	0	1		
Reserved					Type = 240																Length												
EPCDataParameter [See notes below]																																	
ROSpecID Parameter (0-1)																																	
SpecIndex Parameter (0-1)																																	
InventoryParameterSpecID Parameter (0-1)																																	
AntennaID Parameter (0-1)																																	
PeakRSSI Parameter (0-1)																																	
ChannelIndex Parameter (0-1)																																	
FirstSeenTimestampUTC Parameter (0-1)																																	
FirstSeenTimestampUptime Parameter (0-1)																																	
LastSeenTimestampUTC Parameter (0-1)																																	
LastSeenTimestampUptime Parameter (0-1)																																	
TagSeenCount Parameter (0-1)																																	
AirProtocolTagDataParameter (0-n)[See Notes below]																																	
AccessSpecID Parameter (0-1)																																	
OpSpecResultParameter (0-n) [See notes below]																																	
Custom Parameter (0-n)																																	

Figure 3.8: TagReportData parameter binary encoding [54]. TagReportData is generated per tag and contains a mandatory parameter EPCData with encoding

0										1																							2													3			
0	1	2	3	4	5	6	7	8	9	0	1	2	3	4	5	6	7	8	9	0	1	2	3	4	5	6	7	8	9	0	1																		
Reserved					Type = 241																Length																												
EPCLengthBits											EPC																																						

Figure 3.9: EPCData parameter binary encoding [54]. EPCData shall be used for encoding a non-96 bit EPC, whereas the EPC-96 Parameter on figure 3.10 is be used for encoding a 96-bit EPC

0										1																										2													3	
0	1	2	3	4	5	6	7	8	9	0	1	2	3	4	5	6	7	8	9	0	1	2	3	4	5	6	7	8	9	0	1																			
Type=13										EPC[95:72]																																								
EPC[71:40]																			EPC[39:8]																															
EPC[7:0]																																																		

Figure 3.10: EPC-96 parameter binary encoding [54]

3.5.4 Specification (Spec)

There are two main Specs defined in the LLRP Standard: *Reader Operation Specs* (ROSpecs) and *Access Specs*. Most of other Specs and parameters are enclosed under one of the two. I will briefly discuss relevant knowledge required to understand the Specs context. Detailed information on necessary fields will be presented later in opportune moments throughout this dissertation.

Reader Operation Spec (ROSpec)

ROSpecs control the operation of the Reader. They describe the inventory operations the Reader has to perform. A Reader only supports one ROSpec at a time. An example of a ROSpec is presented inside the *ADD_ROSPEC* message seen in Code 1. XML is used in

the context of many LLRP clients to provide human readability of the binary protocol, and also used in this dissertation for the same reason. In the *ADD_ROSPEC* XML message we observe one ROSpec and constituting parameters and fields. ROSpecs contain the following elements:

ROSpecID is an ID set by the client to uniquely identify the Spec in subsequent commands. **Priority** should be set to “0” [86]. By default, all ROSpecs should have the same priority.

High priority ROSpecs can preempt an active lower priority one and start execution as soon as the start condition occurs.

CurrentState describes the current state of the ROSpec - *disabled, inactive, active*. When adding and ROSpec the state must be set to *disable*.

ROBoundarySpec is a parameter containing a description of the start and stop conditions for the Spec. These are the conditions available for the start trigger:

- **None/Null** - ROSpec will not start unless indicated by the client application through an *START_ROSPEC* message;
- **Immediate** - the ROSpec will start immediately after enabled, and will continuously restart itself until disabled;
- **Periodic** - when enabled, the ROSpec will be triggered periodically;
- **GPI** - the enabled ROSpec will start when the GPI event enters a certain state.

Available stop triggers:

- **None/Null** - the ROSpec only stops when stopped by the client through the *STOP_ROSPEC*;
- **Duration** - ROSpec stops when it has been active for a specified duration;
- **GPI** - ROSpec will stop when the GPI event enters a certain state.

Antenna Inventory Spec (AISpec) contains the settings for the Reader’s antennas and Gen2 Air protocol options. An ROSpec can have one or more AISpecs which are executed when the ROSpec runs.

ROReportSpec is optional and describes “when” reports should be forward to the client and “what” the report contains. If not defined, the Reader will use the current or default settings.

```

1  <?xml version="1.0" encoding="UTF-8"?>
2  <ADD_ROSPEC xmlns="http://www.llrp.org/ltk/schema/core/encoding/xml/1.0" Version="1" MessageID="0">
3    <ROSpec>
4      <ROSpecID>666</ROSpecID>
5      <Priority>0</Priority>
6      <CurrentState>Disabled</CurrentState>
7      <ROBoundarySpec>
8        <ROSpecStartTrigger>
9          <ROSpecStartTriggerType>Periodic</ROSpecStartTriggerType>
10         <PeriodicTriggerValue>
11           <Offset>0</Offset>
12           <Period>5000</Period>
13         </PeriodicTriggerValue>
14       </ROSpecStartTrigger>
15       <ROSpecStopTrigger>
16         <ROSpecStopTriggerType>Duration</ROSpecStopTriggerType>
17         <DurationTriggerValue>2000</DurationTriggerValue>
18       </ROSpecStopTrigger>
19     </ROBoundarySpec>
20     <AISpec>
21       <AntennaIDs>0</AntennaIDs>
22       <AISpecStopTrigger>
23         <AISpecStopTriggerType>Null</AISpecStopTriggerType>
24         <DurationTrigger>0</DurationTrigger>
25       </AISpecStopTrigger>
26       <InventoryParameterSpec>
27         <InventoryParameterSpecID>1</InventoryParameterSpecID>
28         <ProtocolID>EPCGlobalClass1Gen2</ProtocolID>
29       </InventoryParameterSpec>
30     </AISpec>
31     <ROReportSpec>
32       <ROReportTrigger>Upon_N_Tags_Or_End_Of_ROSpec</ROReportTrigger>
33       <N>0</N>
34       <TagReportContentSelector>
35         <EnableROSpecID>0</EnableROSpecID>
36         <EnableSpecIndex>0</EnableSpecIndex>
37         <EnableInventoryParameterSpecID>0</EnableInventoryParameterSpecID>
38         <EnableAntennaID>1</EnableAntennaID>
39         <EnableChannelIndex>0</EnableChannelIndex>
40         <EnablePeakRSSI>0</EnablePeakRSSI>
41         <EnableFirstSeenTimestamp>0</EnableFirstSeenTimestamp>
42         <EnableLastSeenTimestamp>0</EnableLastSeenTimestamp>
43         <EnableTagSeenCount>0</EnableTagSeenCount>
44         <EnableAccessSpecID>1</EnableAccessSpecID>
45       </TagReportContentSelector>
46     </ROReportSpec>
47   </ROSpec>
48 </ADD_ROSPEC>

```

Código 1: Example of *ADD_ROSPEC* message in XML representation

3.5.5 Application Flow

A typical LLRP application flow can be seen in figure 3.11. Upon establishing a TCP connection, a Client add and enables an ROSpec containing information about the inventory procedures. The Client can also register an AISpec for Gen2 commands, like writing EPCs and lock tags. The Reader, upon trigger, executes the Specs, performing EPC inventory and tag operations, which are reported back to the Client.

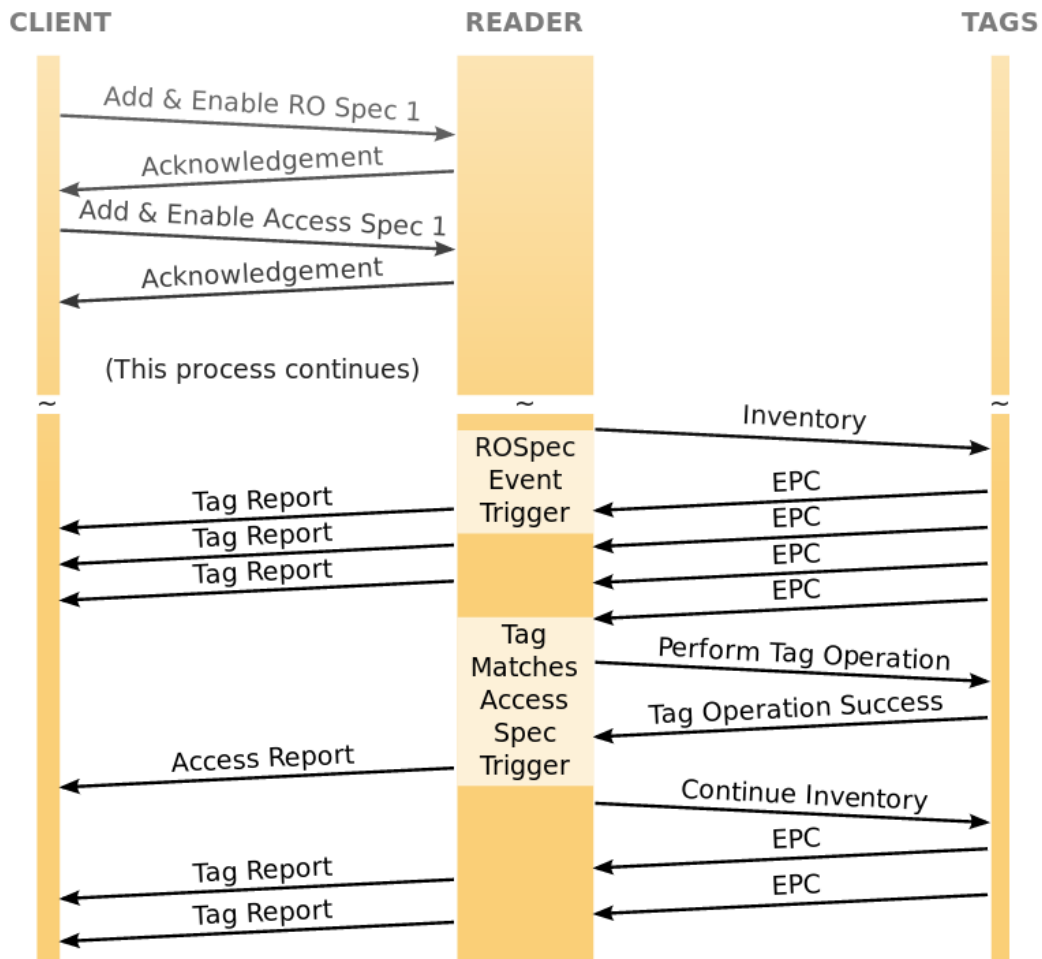

Figure 3.11: Example of LLRP Application Flow [86]

Access Specification

An *Access Spec* handles the extended tag operations of Gen2: read, write, lock and kill. It was design to be extensible, in order to support multiple air protocols and their respective commands. These will not be directly used in the practical context of this dissertation, so no further description will be added.

3.6 FILTER AND COLLECTION (F&C)

F&C is a specification for middlewares operating between readers and client, to receive, filter, translate and deliver data to client applications.

Gen2 RFID readers can generate large amounts of network traffic. The amount of requests generated, containing reports with EPC raw data, can bottleneck most networks, being unsuited for internet data exchanges. Often, client applications are hosted in different networks and even different physical places. With the current paradigm of cloud computing, the interest in processing application data on data centers only seems to be growing. Furthermore, raw EPC data is not “high-level” compared to the paradigm of most business logic in client applications. Client applications, without any middleware, have to process and contextualize huge amounts of data, overburdening services with workloads that are not in their scope of work.

3.6.1 Responsibilities

In the standard specification, EPCGlobal defines responsibilities and interfaces for F&C middlewares. Companies are free to extend these responsibilities and add features in their own implementations.

A F&C middleware must be able to receive raw tag reads from one or multiple RFID readers through an LLRP client interface. These raw tags, in binary encoding format, must be decoded and translated into URI representations, used in client applications.

Tag reads must be processed to reduce the EPC data volume, this includes: filtering, by ignoring EPCs according to subscription patterns; aggregate EPCs over time intervals, eliminating duplicate reads within that interval; summarize and count EPCs in specific object classes; and differential analysis, by reporting which EPCs have been added or removed.

F&C must be able to invoke Gen2 commands on the reader, required by applications to write, lock, kill, and otherwise operate upon tags. F&C should also map readers by *logical reader names* defined by configuration commands and/or files.

Lastly, F&C middleware must expose an ALE interface to provide means for client applications to request EPC data, reader information, control information and configure all F&C aspects described previously.

3.7 APPLICATION LEVEL EVENTS (ALE)

The ALE interface role is to provide independence between the infrastructure components and the applications that use the data. Business applications have access to the lower layers of the infrastructure, like readers and middlewares, without configuring hardware or making low level logical indicators to select data. Succinctly, the interface allows client applications to register and subscribe to their interested EPC patterns and request strategies in a high-level declarative way.

ALE uses a Web Services Description Language (WSDL), an XML based interface used to describe functionality offered by web services, to define, configure and request reports from middlewares and smart readers. The XML schema is defined in a XML Schema Definition (XSD) file. The XSD file expresses a set of rules to which XML documents must conform in order to be considered valid. The interface also defines Simple Object Access Protocol (SOAP)

```

1  <?xml version="1.0" encoding="UTF-8" standalone="yes"?>
2  <ns3:LRSpec xmlns:ns2="urn:epcglobal:ale:wsd1:1" xmlns:ns3="urn:epcglobal:ale:xsd:1">
3    <isComposite>false</isComposite>
4    <readers />
5    <properties>
6      <property>
7        <name>ReaderType</name>
8        <value>org.fosstrak.ale.server.readers.llrp.LLRPA adaptor</value>
9      </property>
10     <property>
11       <name>Description</name>
12       <value>Warehouse reader for inventory management at Aveiro boutique store</value>
13     </property>
14     <property>
15       <name>PhysicalReaderName</name>
16       <value>ImpinjSpeedwayShelve1</value>
17     </property>
18     <property>
19       <name>ip</name>
20       <value>169.254.1.1</value>
21     </property>
22     <property>
23       <name>port</name>
24       <value>5084</value>
25     </property>
26     <property>
27       <name>clientInitiated</name>
28       <value>true</value>
29     </property>
30   </properties>
31 </ns3:LRSpec>

```

Código 2: Example of *LRSpec* used to register a single Reader named *ImpinjSpeedwayShelve1* with Internet Protocol (IP) 169.254.1.1

bindings on top of the WSDL, for the callback interfaces of the reading and writing Application Programming Interfaces (APIs).

3.7.1 Specifications and Reports

To configure and subscribe to interested EPC patterns, client applications must first register *logical readers* using a *Logical Reader Spec (LRSpec)*. An example can be seen in Code 2. *LRSpecs* are basically readers registration forms.

To subscribe to EPC data, clients register *Event Cycle Specs (ECSpecs)*. *ECSpecs* take inspiration from the same ideas as in LLRP, by describing event boundaries, filtering and subscription patterns, aggregation rules and differential analysis report options in a truly high-level form. One example can be seen in Code 3. The example subscribes to EPC data from the logical reader *Reader_Shelve1*. The middleware should send back to the client two types of reports every 5 seconds: one reporting all EPC tag-URIs added to the reading zone of the reader; and other reporting all EPC tag-URIs removed from the reading zone with a count of total removed tags. A complex *ECSpec* with subscription patterns will be presented in next chapters, in the practical implementation sections of this dissertation.

Subsequently, client have to indicate where the *ECSpecs* reports should be delivered, by

```

1  <?xml version="1.0" encoding="UTF-8"?>
2  <ns2:ECSpec xmlns:ns2="urn:epcglobal:ale:xsd:1">
3    <logicalReaders>
4      <logicalReader>Reader_Shelve1</logicalReader>
5    </logicalReaders>
6    <boundarySpec>
7      <repeatPeriod unit="MS">5000</repeatPeriod>
8      <duration unit="MS">5000</duration>
9      <stableSetInterval unit="MS">0</stableSetInterval>
10   </boundarySpec>
11   <reportSpecs>
12     <reportSpec reportName="additions">
13       <reportSet set="ADDITIONS" />
14       <output includeTag="true" />
15     </reportSpec>
16     <reportSpec reportName="deletions">
17       <reportSet set="DELETIONS" />
18       <output includeTag="true" />
19     </reportSpec>
20   </reportSpecs>
21 </ns2:ECSpec>

```

Código 3: *ECSpec* example used in early stages of the practical work of this dissertation

```

1  <?xml version="1.0" encoding="UTF-8" standalone="yes"?>
2  <ns2:ECReports terminationCondition="DURATION" totalMilliseconds="3003"
3  ↪ ALEID="ETHZ-ALE-1001980346" date="2020-07-15T15:44:20.651Z"
4  ↪ specName="ec_warehouse_shelve1" xmlns:ns2="urn:epcglobal:ale:xsd:1">
5  <reports>
6    <report reportName="deletions">
7      <group>
8        <groupList>
9          <member>
10             <tag>urn:epc:tag:sgtin-96:1.76300544.07630.1</tag>
11             <tag>urn:epc:tag:sgtin-96:1.76300544.07470.5</tag>
12             <tag>urn:epc:tag:sgtin-96:1.76300544.07470.6</tag>
13           </member>
14         </groupList>
15         <groupCount>
16           <count>3</count>
17         </groupCount>
18       </group>
19     </report>
20   </reports>
21 </ns2:ECReports>

```

Código 4: Example of *ECReport* generated by the *ECSpec*'s *deletions* Report Spec in Code 3, where a three tags were removed from the reading zone

indicating a NotificationURI. These reports are named *Event Cycle Reports (ECReports)* and an example can be seen in Code 4.

3.8 CAPTURE APPLICATION

In the *EPCGlobal Framework*, the Capture Application role serves to contextualize EPC data from *ECReports* into EPCIS data, and send it to an EPCIS repository to be stored.

Capture Applications requirements are not further specified by the *EPCGlobal Framework*.

From what I have encountered, generic capture applications implement dynamic run-time rule engines, to specify business logic in an high-level context (e.g. Java Drools). Many integrate interfaces for other device-generated data such as bar codes, matrix data (e.g. QR Code), human input and data gathered from other software systems. Business logic in capture applications can be complex: retail capture applications can implement anti-thief mechanism, predict out-of-stock situations, infer clients shopping experience and gather data for machine learning services (e.g. to infer client interests) [87].

3.9 EPC INFORMATION SERVICES (EPCIS)

EPCIS enables enterprises to create and share EPC related data with trading partners. The standard was conceived as part of a broader effort to enhance collaboration between trading partners, to create visibility of physical and digital objects within relevant business contexts [88].

3.9.1 Data Model and Core Business Vocabulary (CBV)

To ensure conformity in data shared across systems, the EPCIS standard defines a data model. This allows disparate application to operate under coherent data structures capable of provide visibility in relevant business operations.

EPCIS structures the real-world business information as a sequence of individual business processes. Business processes can vary. From packaging product, packing into a shipping container, shipping, receiving, and so forth. Each completion of one of these business process is modeled by an EPCIS Event.

An EPCIS Event is the basic unit of data in the EPCIS data model. It provides a detailed picture of a business processes by organizing its contents into four dimensions: *What*, *When*, *Where* and *Why*.

The *What* dimension identifies the physical and digital objects involved in the event. It uses the EPC TDS schemes, seen previously, to do so. On section 3.4, we talked about EPC and how it encodes information about the physical object it refers to. We focused on SGTIN for item level identification, but different GS1 Keys exist to identify a multitude of SCM assets: like pallets, batches and lots, returnable assets, to say a few (see Appendix 8.2).

When dimension records when the event took place. It contains three elements: **Event Time** containing the date and time at with the event took place; **Event Time Zone Offset** indicating the time zone at the place and time of the event; and **Record Time** which saves the date and time of when the EPCIS event was recorded into an EPCIS repository.

Where dimension, as it implies, captures where the event physically took place and/or where are the objects following the event. The dimension allows for two location types: **Read Point** and **Business Location**. The **Read Point** is the location where the event took place. The **Business Location** is the location where the objects reside after the event.

Locations are preferably identified by a GLN. A GLN is a GS1 Identification Key used to identify physical location like factories, businesses and facilities [81]. GLNs are often

urn:epc:id:sgln:76300544.00000.1

Company Prefix Location Reference Extension

Figure 3.12: Example of GLN with extension (SGLN) in URI format. In the practical context of this dissertation, identifies the improvised shelve reading point in a Nespresso boutique store

accompanied by an extension used to identify internal physical locations within a location already identified by a GLN. An example of a GLN can be seen in figure 3.12.

The *Why* dimension describes the context of the business process in which the event took place. This dimension includes a multitude of parameters, which are included in the EPCIS Event as a combination of such ⁴:

- **Business Step** identifies what was taking place from a business context (e.g. `packing`, `shipping`, `inspecting`, `retail_selling`).
- **Disposition** identifies the business condition ensuing the event of the object (e.g. `recalled`, `retail_sold`, `in_transit`, `stolen`).
- **Business Transaction List** identifies business transactions relevant to an event. It is described by a pair of identifiers: `Business transaction type` which identifies the type of transaction; and `Business transaction ID`, an ID that identifies a specific transaction.
- **Source** and **Destination** are used to provide additional business context when the event is part of a business transfer of ownership, responsibility or custody.

The possible values of these parameters are standardized under the CBV Standard, which operates in association with the EPCIS to provide common and standardized business vocabulary [58]. The CBV, much like most of *EPCGlobal Framework*, uses a URI syntax has parameter values. An example of a populated EPCIS Event can be seen in table 3.8.

⁴Some of parameters change between EPCIS and CBV versions due to reformulations in both standards

Dim	Data Element	Design Choice (Section 4.6)	Actual EPCIS Event Contents
	Event Type	Object Event	
	Action	OBSERVE	
What	EPC List	A list containing one element: the SSCC of the pallet (instance-level identification)	urn:epc:id:sscc:0614141.0123456789
When	Event Time	The date and time at which the pallet is shipped	2014-03-15T10:11:12Z
	Event Time Zone Offset	The time zone offset in effect where the pallet was shipped	-05:00
Where	Read Point	Shipping dock #2 of building 10	urn:epc:id:sgln:0614141.11111.2
	Business Location	(omitted)	(omitted)
Why	Business Step	Shipping (from CBV)	
	Disposition	In Transit (from CBV)	
	Business Transaction List	A list containing two business transaction references: the Retailer's purchase order and the Manufacturer's invoice.	<i>Type</i> urn:epcglobal:cbv:btt:po urn:epcglobal:cbv:bt:5012345678900:1234 <i>Type</i> urn:epcglobal:cbv:btt:inv
	Source List	A list containing one source of type "owning party," indicating the Manufacturer as the owning party at the source	<i>Type</i> urn:epcglobal:cbv:sdt:owning_party urn:epc:id:sgln:0614141.11111.0
	Destination List	A list containing one source of type "owning party," indicating the Retailer as the intended owning party at the destination	<i>Type</i> urn:epcglobal:cbv:sdt:owning_party urn:epc:id:sgln:5012345.67890.0

Table 3.8: EPCIS Event Information Content example from the business process of shipping a pallet [88]

3.9.2 Event types

To allow for more flexibility and variations in the structure of the *What* dimension, EPCIS defines a few variations of the basic EPCIS Event:

- **ObjectEvent** is the most simple and commonly used. It represents an event that happened to one or more objects (e.g. shipping a pallet using a SSCC).
- **AggregationEvent** represents an event that happened to physically aggregated objects (e.g. aggregating cases in to a pallet, or removing cases from a pallet).
- **TransformationEvent** represents an event in which the input objects are fully or partially consumed to produce output objects (e.g. processing raw materials in a product to be commercialized).
- **TransactionEvent** represents an event in which one or more objects become associated or disassociated with one or more business transactions (e.g. linking a pallet and cases to a commercial invoice)

```

1 <epcis:EPCISDocument xmlns:epcis="urn:epcglobal:epcis:xsd:1">
2   <EPCISBody>
3     <EventList>
4       <ObjectEvent>
5         <eventTime>2015-07-15T10:00:00.000-05:00</eventTime>
6         <eventTimeZoneOffset>-05:00</eventTimeZoneOffset>
7         <epcList>
8           <epc>urn:epc:id:sgtin:0614141.012345.101</epc>
9           <epc>urn:epc:id:sgtin:0614141.012345.102</epc>
10          <epc>urn:epc:id:sgtin:0614141.012345.103</epc>
11        </epcList>
12        <action>OBSERVE</action>
13        <bizStep>urn:epcglobal:cbv:bizstep:transporting</bizStep>
14        <disposition>urn:epcglobal:cbv:disp:in_transit</disposition>
15        <readPoint>
16          <id>geo:41.6725,-86.255278</id>
17        </readPoint>
18        <example:TemperatureC>15</example:TemperatureC>
19        <example:RelativeHumidity>80</example:RelativeHumidity>
20      </ObjectEvent>
21    </EventList>
22  </EPCISBody>
23 </epcis:EPCISDocument>

```

Código 5: Example of an EPCIS Report sent to a EPCIS capture interface. EPCIS Reports can be extended with User/Vendor Extensions. In this example we see a `TemperatureC` and `RelativeHumidity` vendor extensions

3.9.3 Capture and Query Interfaces

To complement the data model, EPCIS also standardizes two interfaces: a *Capture interface* that allows client to send EPCIS Events, to be saved, typically in a persistent repository of EPCIS data, called EPCIS repository; and a *Query interface* from which EPCIS data may be requested by applications and trading partners.

The data shared between clients and these interfaces is expressed in XML. EPCIS provides XML bindings for the data models described previously. The *Capture interface* can be used with either message queue or Hypertext Transfer Protocol (HTTP). In Code 5 can be seen an XML EPCIS Event example sent to a capture application.

EPCIS *Query interface* is defined as a web service and can be interacted with by the SOAP transport mechanism using the following available operations:

- `poll`: queries for EPCIS events matching specific criteria.
- `subscribe`: allows client to register a subscription for events matching specific criteria, which are delivered asynchronously to the client.
- `unsubscribe`: removes a registered subscription.
- `getQueryNames`: returns a list with the supported types of queries supported by the service.
- `getSubscriptionIDs`: returns a list of active subscriptions.
- `getStandardVersion`: return the EPCIS version supported by the service.

```

1 <soap:Envelope xmlns:soap="http://schemas.xmlsoap.org/soap/envelope/">
2   <soap:Body>
3     <epcisq:Poll xmlns:epcisq="urn:epcglobal:epcis-query:xsd:1">
4       <queryName>SimpleEventQuery</queryName>
5       <params>
6         <param>
7           <name>eventType</name>
8           <value>
9             <string>ObjectEvent</string>
10          </value>
11         </param>
12         <param>
13           <name>EQ_bizLocation</name>
14           <value>
15             <string>urn:epc:id:sgln:76300544.00000.0</string>
16          </value>
17         </param>
18       </params>
19     </epcisq:Poll>
20   </soap:Body>
21 </soap:Envelope>

```

Código 6: Example of EPCIS Query requesting all ObjectEvents from the Business Location urn:epc:id:sgln:76300544.00000.1

- `getVendorVersion`: returns a vendor string identifying any non-standard extensions supported by the service (e.g. `TemperatureC` and `RelativeHumidity` vendor extension in Code 5)

A simple poll operation can be seen in Code 6. Inside the SOAP envelope we can observe a poll operation requesting every `ObjectEvent` collected by the reading point urn:epc:id:sgln:76300544.00000.1.

In the next chapter I will present the state of the art of RFID smart shelves, purpose hardware and research.

RFID Smart Shelves

RFID enabled smart shelves, or intelligent shelves, are shelves, racks or cabinets that are equipped with RFID capabilities. Tagged objects placed on these shelves can be inventoried and monitored in real-time, to solve common problems related with inventory management.

Smart shelves solve a multitude of problems across multiple industries. A few advantages offered by smart shelves are listed bellow [15], [89]–[91]:

- Get timely accurate replenishment of products, avoiding stock-outs and better management of inventory. It can ensure availability of products and automated control of expiration dates, useful in multiple industries to keep accurate stock information and control of products. In markets of volatile products (e.g. low quantity batches, perishable goods with short shelf life, products with high volatile prices), RFID services can ensure timely deliveries and automation of orders.
- Optimise in-store sales and management by reducing time and errors from manual labour counts, identify misplaced and lost or stolen items. Bridges online and physical stores inventories, maintaining accurate visibility of product availability. RFID also helps customers find and engage with the products they want.
- In industries working with valuable tools and materials (e.g. hospitals, research centers), it can help control who removes or checks out valuable items, and locate them in a timely manner.
- Enable retailers to better understand product sale potential, by analysing data generated from smart shelves displaying sale items.
- Create visibility and automate SCM. Enterprise back-end systems (e.g. machine learning services) can infer and automate optimal product distribution, predict market changes and necessities, which otherwise had to be anticipated by management teams.

4.1 COMMERCIAL SOLUTIONS

There are multiple commercial RFID smart shelves available on the market. The most prominent sector has been the health industry, with smart RFID-enabled cabinets [92]–[95],

where in conjunction with technologies like the *EPCGlobal Pedigree* standard [64], maintains accurate inventory and ensures only authentic pharmaceutical products are distributed through the supply chain. In the following subsections, I will present generic smart shelves currently commercialized which use RFID in their solution.

4.1.1 Keonn: AdvanShelf™

Keonn, a leader in UHF RFID systems for retail stores and intelligent spaces, commercializes the *AdvanShelf™*. The *AdvanShelf™* is a UHF smart shelf system designed for real-time location of items [96]. The system was designed to be invisible, incorporated into metallic, plastic and wood-made shelves. It includes an RF multiplexer, which can connect up to 1024 antennas to one reader, location software with a resolution of ± 40 cm and Keonn Java drivers for system integration.

They also commercialize RFID-enabled lockers, shown on figure 4.1, based on the *AdvanShelf™* RFID solution of readers, antennas and multiplexers.



Figure 4.1: RFID-based electronic lockers from Keonn based on the *AdvanShelf™* solution [97]

4.1.2 CribMaster: AccuCab and AccuDrawer

CribMaster, a company focused on intelligent inventory management, mainly for industrial hardware, commercializes two inventory systems: *AccuCab* and *AccuDrawer*. The *AccuCab*, shown in figure 4.2a, is their solution for tool access control and storage. It has pull-out shelving for easy access, and is ideal for storing heavy items like power and hand tools. The *AccuDrawer*, shown in figure 4.2b, is the same product in a drawer configuration. They use passive RFID tags, and no further specifications are given.



(a) CribMaster AccuCab inventory system cabinet (b) CribMaster AccuDrawer smart storage control solution [98]

Figure 4.2: CribMaster RFID inventory management solutions

4.1.3 Fabmatics: RFID Rack

Fabmatics is a company specialized in material flows and handling processes in industries with high cleanliness requirements (e.g. semiconductor industry, pharmaceutical industry, photovoltaics and large-scale laboratories), where it integrates their products in the client's production environment [100]. They offer a retrofitted RFID storage systems for silicon wafers, shown in figure 4.3. No further RFID technological specifications are provided.



Figure 4.3: Fabmatics RFID Rack design for wafer storage [100]

Surprisingly, many smart shelves in the market do not depend on RFID technology for inventorying, but on other technologies like image processing, IoT and machine learning to do so [101], [102].

4.2 ACADEMIC SOLUTIONS

Smart shelves have been approached by a few students and researchers in their work over the years. Overall, the UHF RFID research targeted, mostly, antenna design and item location. Nothing was found on smart shelves with *EPCGlobal Framework* integration, apart from a paper where EPC was used in Gen2 UHF tags to evaluate point of sale smart shelves [103].

The prominent applications of smart shelves, by academic researchers, has been in the health industry, with smart cabinets [104]–[107] and RFID-based smart blood stock systems [108], and in RFID library managements systems [109]–[112]. Both areas of application used HF or UHF RFID in their implementations, fortifying the decaying LF RFID technology, which was predominant in both areas.

For more generic implementations, Andrea D’Alessandro, in his PhD thesis, has studied and developed UHF RFID-based smart shelving storage systems with location capabilities [105]. He studied location techniques for UHF RFID smart shelves, employing “off the shelf” hardware components in different arrangements.

Other researches employed similar techniques to identify and locate items on shelves using UHF RFID, mainly focusing on antenna design applications and item location techniques [113]–[116]. In particular, over the last years, a huge amount of study has been put in development and research of antennas for *near-field* UHF RFID, intended to be used in smart shelves and similar purposes [116]–[134]. A lot of time was invested in research of this topic throughout the beginning of this dissertation, but abandoned in favor of implementing a prototype which integrates the *EPCGlobal Architecture Framework* technologies.

There have been a few out of the box implementations using 3D localization of UHF RFID-tagged products by ground robots and drones with commercial off-the-shelf RFID hardware [135].

Research was also put on developing cheaper and better open UHF hardware based on commercial IC chips [136]–[138] and FPGAs [139].

In the next chapter I will contextualize the dissertation, address requirements, present development options and their peculiarities in respect to performance, cost and development time.

Contextualization and Development Plan

5.1 CONTEXT

In the previous chapter I presented the state of the art of smart shelves. To understand the context of the implementation presented throughout the remaining of this dissertation, a brief contextualization of the use case and background is needed.

The smart shelf developed in this dissertation was primarily designed to integrate warehouse storage in Nespresso boutique stores. Nespresso is a company owned by Nestlé Nespresso S. A., one operational unit of the Nestlé Group, dedicated to the retail and production of coffee capsules, coffee machines and related accessories. Coffee arrives from different parts of the globe (Colombia, Brazil, Ethiopia, India, Indonesia, to say a few) through seaborne container, reaching the factories by train. The company has 3 manufacturing facilities producing coffee capsules in Switzerland, from where it dispatches products to supply chain centers. Coffee machines are manufactured in East Europe and from there, shipped to supply chain centers. Supply chain centers distribute the products to retail and boutique shops where they are sold [140].

The complexity in the logistics network, due to the growing of the brand, starts to compromise the management of the products down in the chain. Namely, in boutique stores, the categorization and verification of new inventory, inspection of the arrived goods from the transportation company, returns, control and management of stocks, are all attended by manual labour. The manual labour is prone to errors and requires a lot of working hours.

5.2 REQUIREMENTS

The solution to develop in this dissertation must solve the problems presented previously. It must be able to compose a periodic inventory of the items in stock and provide means to store and query that data, preferably in a standardized manner following supply chain



(a) Nespresso coffee sleeve, machine and accessories



(b) Nespresso sleeves and outer cardboard packing used in distribution

guidelines and practices. This inventory should be presented and displayed in a suitable user interface. It must be reliable and reasonably cost efficient to maintain.

Regarding Nespresso's inventory specifications, their catalog ranges in products and packing levels. Nespresso boutiques store in their warehouses:

- **Coffee capsules** composed of an aluminum outer shell, and sold in $28 \times 3.6 \times 3.8$ cm thin cardboard sleeves, shown in figure 5.1a. The sleeves are distributed packed inside $29 \times 19.6 \times 16$ cm cardboard boxes, shown on figure 5.1b. These boxes pack 20 sleeves of a single coffee variation.
- **Coffee machines** made of mostly plastic and metal. Size and packing can vary.
- **Accessories** which can range from espresso cups, mugs, storage boxes, dispensers, aeroccinos, chocolates, spoons and bowls, to say a few. These are made of a variety of materials, like stainless steel and porcelain.

The software platform implementation should be agnostic, in that it runs equally well across multiple platforms. It should be capable of effortlessly integrate with the logistics management software and services used by the company and trading partners.

5.3 SOLUTION

The solution proposed in this dissertation is a system of smart shelving, where the goods like coffee capsules, machines and accessories are stored. These goods are tagged with RFID tags and integrated in an RFID-enabled supply chain. The shelf structure contains RFID antennas and readers that detect and read the tags attached to the stored products. Readers will send real-time state and changes of inventory to the software platform, which filters and contextualizes the data, stores it, and provides appropriate query interfaces to managing

software systems. This system can solve multiple issues and in the future integrate multiple features like:

- Prevent stock-outs and get timely replenishment of products. Logistics companies deliver goods on time and according to delivery requirements generated automatically by a management system;
- Reduce time and errors from manual labour: counts, identification, misplacement and lost or stolen items;
- Control who removes or checks out valuable products;
- Automate information about stock predictions. Manufacturer production lines automatically transmit and receive re-stock interest information.
- Handle registration and verification of arriving stock. Automatically identify goods in the warehouse/shelves and match them with distribution invoices;
- Verify products trades as goods enter the collection area. The collection equipment automatically identifies items, by collecting RFID tags, thereby ensuring the physical and distribution requirements are consistent;
- Monitor in real-time the distribution of all goods, accurately know inventory state and grasp the status and changes of the warehouse environment in real time.

In the design and planning of this solution, there are two different contexts considered. The first is how a real product would be designed to be ready for the envisioned environment. Costs, deployment problems and architecture designs should be well thought in order to achieve a stable and commercially appealing product. The second context is a generic prototype implementation showing a working proof of what the real product would be like. In a real-world implementation, sleeves would not be tagged, as it would increase significantly operation costs without significant benefits. For academic purposes of studying tag density read performance, each sleeve was tagged.

In the remaining of this chapter I will discuss and show multiple development options: hardware, product design and platform software. In the last section of this chapter, I will present and clarify the options taken to prototype the smart shelf solution accomplished in this dissertation.

5.4 RFID TECHNOLOGY

It was clear, early in the researching for this dissertation, that the RFID technology which would be used was UHF. It is the most reasonable option in this context: it has the reading distance requirements necessary for the solution envisioned; it provides the cheapest and best performance tags, with promises of even cheaper, more robust and efficient in the future; and most important, it is the RF technology used in Gen2 tags and SCM systems deployed around the globe. Would not make sense to diverge from the well established implementations and difficult the integration in logistics and supply chain systems. In fact, it would create a technological frontier and incompatibility in respect to tag technology. With this, there is no further critical incentive to opt for other RFID technology other than UHF RFID.

5.5 READERS

5.5.1 Considerations

To buy commercial readers or make a custom implementation? The answer is deeply dependent on company long term plans, namely in the balance between R&D cost, return on investment, and long term benefits. Compromises in engineering work have to be clearly balanced with the company needs and requirements. If the RFID implementation plans extend deeply into the organization - points of sale, distribution centers, warehouses and manufacturing - making a custom reader solution might make sense, when evaluating cost margins and requirements. For companies like Walmart, Decathlon and big retailers, the investment in custom hardware should definitely be considered.

Commercial readers tend to be very expensive. They are usually designed for generic applications, providing incredible reading distances, astonishing number of tag reads per second, and multiple other features to please every client and fit every application. This makes them rather expensive and excessive for applications like smart shelves.

Smart shelves, in most design approaches, do not require high power transmission nor high tags reads per second. Designs usually take advantage of RF splitters and multiplexers to connect multiple antennas. They could also take advantage of WiFi, LTE and PoE capabilities, over the traditional communication interfaces like the serial port.

Returning to the main premise, there are two paths which can be followed: development of a custom reader ¹ or adopt a commercial one. Custom designs for smart shelves can be much cheaper: less features translate to few hardware requirements; lower power transmission allows cheaper RF amplifiers (commercial readers can read up to $10m$, and depending on shelf implementations, we might only require reads up to $1m$); lower requirements in reads speeds allow cheaper EPC C1G2 SMD or chip solutions, like ICs designed for handheld readers, which tend to be less powerful but cheaper. On top of being cheaper, custom readers allow developers to implement features otherwise nonexistent. Many readers expose interfaces mainly through Java and C# SDKs. Open standards like LLRP are usually provided only in few high-end commercial readers. The stagnant condition of commercial readers, also does not keep up with new IoT and IT technologies, which have showed to be incredible powerful, mainly in the distributed computing, and dismissed in favor of legacy technologies. Custom readers can also integrate middleware capabilities (i.g. “smart readers” conceptualized in the *EPCGlobal Architecture Framework*), and capture application features, encouraging a deprecation of discrete middleware and capture applications in a few contexts. On the other hand, the development of such readers is R&D intensive. For small and medium companies, such option is not remotely reasonable. For big companies, this kind of project would certainly be approached by consulting companies, since RFID hardware is not within the expertise of most SCM and retailers. Companies like Nike, Zara and Walmart have built in-house tools and outsourced hardware, strengthening the proposition I am presenting.

¹When I address the development of custom readers, I do not specify who and how, as it can be done by consulting companies or in house. In this dissertation I only discuss development considerations and not how those are translated to engineering work





Manufacturer	Impinj	STMicroelectronics	Nordic	ThingMagic
Name	RS1000	ST25RU3993	NUR-05W	Nano (uses Impinj chips)
Photo				
Antenna Ports	Single mono-static	2 (one differential low-power and one high power)	4 MMCX antenna ports (in dev kit)	1
Interfaces	UART configurable up to 921.6 kbaud	5Mbit SPI	UART and USB 2.0 full speed	UART
Transmit Power (dBm)	+10.0 to +27	Up to +20	Up to +27	Up to +27
Read rate (tags/s)	Up to 230	700 (16-bit EPC)	Up to 200	Up to 200
Sensitivity	-75 dBm	-90 dBm	-82 dBm	Not Published
Price	\$129	1 → 36.40€ 250 → 27.55€	132.21€ excl tax	\$131

Table 5.1: Available EPC C1G2 reader chips and SMD modules on the market. Information and prices gathered from respective datasheets, AtlasRFIDstore [149] and Mouser [150].

5.5.2 Market Offer

The market of RAIN RFID Gen2 compatible readers is extensive, but not very divergent in hardware implementations, in that most readers are based on just a few commercial EPC C1G2 IC chips.

Currently, the EPC C1G2 reader chips available on the market are listed on table 5.1. The considerable market leader is Impinj, which commercializes their own readers and development kits, with their in-house reader chips [141]. Most commercial readers available on the market (e.g. CAEN RFID and Jadak ThingMagic modules [142]) use their chips. There are other players in the EPC C1G2 reader chip market. STMicroelectronics acquired Austriamicrosystems' NFC and RFID reader assets in 2016 [143]. Austriamicrosystems provided, the now discontinued AS3990 (i.g. ST25RU3991), AS3990 (i.g. ST25RU3992) and AS3980 (i.g. ST25RU9080) used by academics to create cheap C1G2 readers [136], [137], [144]. Currently STMicroelectronics commercializes their ST25RU3993 chip [145], used in their evaluation boards and in few commercial readers, like Feig's [146]. There are also companies selling EPC C1G2 SMD reader/writer modules, namely Nordic, with the ID NUR [147], and ThingMagic with the M6e, Micro and Nano [148].



Manufacturer	Impinj	Alien	Zebra
Name	Speedway 420	ALR-9680	FX7500
Photo			
Antenna Ports	4	4	4
Interfaces	RS-232, ethernet (PoE)	RS-232, LAN TCP/IP	Ethernet (PoE)
RF Power Trans (dBm)	+10.0 to +31.5 (EU1 limited to +30)	Up to +36/4W (US), +33/2W ERP (EMA, CHN)	Up to +31.5
Read rate (tags/s)	Up to 1,100	Not Published	Not Published
Sensitivity	-84 dBm	Not Published	-82 dBm
Price	\$1,585	\$852	\$1,094

Table 5.2: EPC Class 1 Gen2 compatible readers well established on the market. Information and prices gathered from respective datasheets and AtlasRFIDstore [149].



(a) Impinj RS1000 development kit (End-of-Life announced on September 4, 2020) (b) STMicroelectronics ST25RU3993 evaluation board (\$306.25 at Digikey)

Regarding commercially available readers, there is an extensive variety of solutions, too many to discuss in this dissertation. An overview of established, widely deployed readers can be seen in table 5.2. Alien Technology, has been commercializing their own RFID readers [151] for years, having a well established client base. Impinj, Fujitsu, Honeywell, ZIH Corp, Mitsubishi, Omron, Takaya, Toshiba, Tyco Sensormatic and Zebra also have EPC C1G2 reader solutions, most of them with LLRP interfaces.

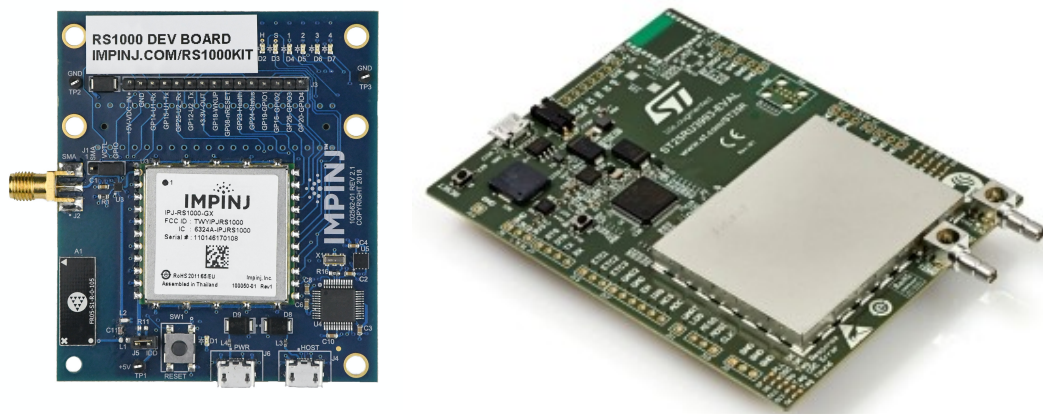

Manufacturer	Keonn	HARTING	Times-7
Name	Advantenna-p33	LOCFIELD	SlimLine A5060
Photo			
Operating Frequency	FCC (902-928 MHz), ETSI (865-868 MHz)	FCC (902-928 MHz), ETSI (865-868 MHz)	FCC (902-928 MHz), ETSI (864-868 MHz)
Polarization	Circular	Linear	Right hand circular
Gain (dBi)	9.6 (US), 10.4(EU)	7.0	10.5 dBic
Elevation Beamwidth	40°	360°	25°
Azimuth Beamwidth	40°	360°	60°
Price	\$342	\$359	\$254

Table 5.3: A few UHF RFID compact antennas available on the market. Information and prices gathered from respective datasheets and AtlasRFIDstore [149].

5.6 ANTENNAS

The discussion between custom and commercial readers made previously, can also be transposed to the selection of antennas. In certain conditions, the development of custom solutions can present good incentives.

Most smart shelves implementations, require mainly antenna designs tuned for the EM *near-field* region. In section 4.2, I cited numerous implementations of *near-field* UHF RFID antennas, intended to be used in smart shelves and similar purposes, by the academic personnel. Many of these present suitable performance to be integrated in smart shelf systems, are simple, easy to manufacture and are much cheaper than commercial alternatives.

Regarding commercial availability solutions, the market offers generic high performance antennas and designs for most applications, having a wider range of specific, single-purpose products, compared to the UHF reader market. High performance antennas tend to be expensive due to the strong requirements in reading distances. Single-purpose antennas are also expensive, intrinsic to their narrower market share. In table 5.3 it is shown a few compact commercial antennas considered for the implementation of this dissertation.

When selecting antennas, it is important to take in consideration their polarization. Systems where the tag orientation is unpredictable, which is the case of most smart shelves, the selection of circular antennas is desirable. Alternatively, two or more linear antennas can be used to mitigate the orientation problem. Even with circular antennas, tag orientation can affect readings in certain conditions, being advisable to prototype and test with different antenna models and placement, in extreme operational conditions.

The approach taken in antenna selection is similarly to reader selection, in that it depends on company approach to such endeavor and product design, which I will be discussing next.

5.7 ARCHITECTURAL DESIGN

Smart shelves can be implemented and designed in different manners, varying in number of antennas, their position, size and power transmitted. D’Alessandro, in his PhD thesis [105], prototyped and evaluated a few possible implementations, which were taken in consideration in planning and designing the shelf developed in this dissertation. In this section I will present a few architectural designs for UHF RFID-enabled smart shelves, how they differ, and discuss a few implementation considerations.

The first design, shown in figure 5.3, is the simplest of all. It can be implemented with a single reader and two antennas. The figure shows a top view of a shelf with an external antenna, radiating at an angle. Variations of this design can be found in retail stores, with ceiling antennas pointing to shelves. The simplicity and functionality of this design is what makes it appealing and fairly adopted. Problems in this arrangement emerge mainly due to tag-to-tag interference and RF obstruction zones, which can appear due to interference from certain materials (see table 2.1).

With two antennas at different angles, it is possible to locate objects with decent accuracy, using metrics² provided by readers, and classification algorithms, using reference tags attached to strategic places of the shelves [105].

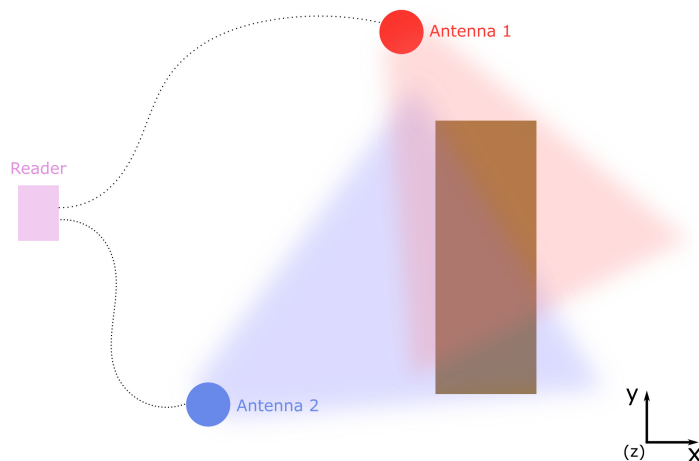

Figure 5.3: Top view of two external antennas radiating a shelf at different angles

Figure 5.4 shows the most frequent approach when designing smart shelves, by placing one or multiple compact antennas in each shelf. These antennas can be incorporated into a shelf, making it invisible and ideal for point of sale in retail stores. Reading zones can be very precisely distributed, creating less RF “polution”, desirable in contexts like shared warehouses in malls, where other RFID system might be deployed. The location techniques described in the first arrangement can be adapted and implemented in similar manner in this design.

This implementation has the downside of requiring multiple antennas, usually connected to a reader by RF splitters and multiplexers. These hardware requirements make this design

²Most commercial readers provide RF metrics like RSSI, Time Difference of arrival (TOA), Angle of arrival (AOA), Phase Difference of Arrival (PDOA)

fairly expensive, being a good example of where custom hardware design is encouraged.

This design has been used in products like the ones in chapter 4, library management shelf systems [110] and in smart lockers.

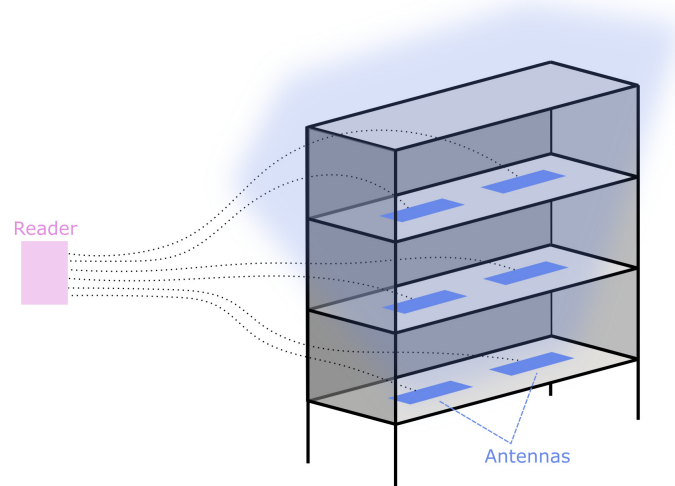

Figure 5.4: Arrangement with multiple compact antennas distributed in each shelf radiating upwards

In conclusion, the last arrangement we will discuss is shown in figure 5.5. It places two antennas per shelf, one in each side of opposing laterals. This approach can be implemented without the use of necessarily compact antennas and favors long shelf designs. This design has been used primarily in library shelf implementations [109].

Similarly to the last design, it presents the downside of requiring multiple reader ports or RF multiplexers. Uniquely to this design, it requires to have antenna designs tuned for both *far* and *near-fields*.

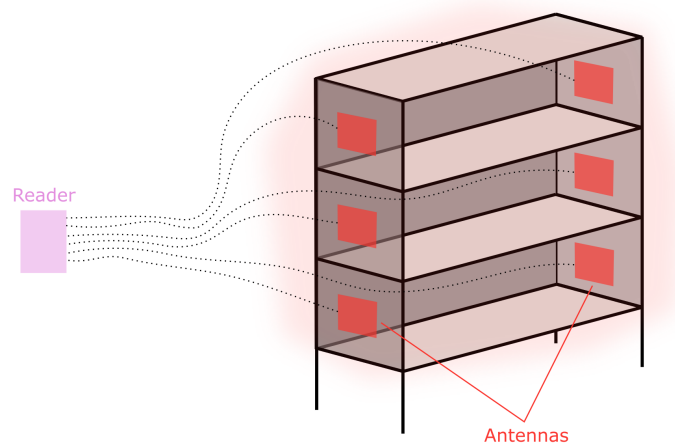

Figure 5.5: Arrangement with two antennas per shelf, one in each side of opposing laterals radiating inwards

5.8 SOFTWARE

5.8.1 Reader Interface Software

Interaction with UHF readers is uniform across the industry. Reader manufacturers generally make Java, C++ and C# SDKs available for commercial and chips reader solutions. These SDKs allow integrators to configure and interact with these through high level APIs, which usually abstract the Gen2 air protocol. SDKs can also expose low level APIs to precisely control the reader and tune the air protocol.

LLRP-compliant readers can use LLRP client programs, like the Fosstrak LLRPCommander [152], based on Eclipse 3.3, to manage and receive tag information. There are also libraries available to decode and encode LLRP messages, which can be used to make LLRP clients. A few of those worth mention: `sllurp` and `pyllrp` implemented in Python, LLRP Toolkits (LTKs) in Java, Perl and C [153] and `go-llrp` implemented in Golang.

To encode, decode and translate EPCs data, there are many available libraries, namely, used in this dissertation, the `epc-standards` EPC decoding Java library from Nike [154], and Fosstrak Java TDT Engine [155].

5.8.2 Software Platform

The availability of software resources for the *EPCGlobal Architecture* is very limited. For years, the only software came from Fosstrak Open Source RFID Software Platform, which provided an ALE F&C Middleware, Capturing Application and EPCIS Repository implementations. Fosstrak last commits to most of the projects dates back 5 years. The technology is outdated, with bugs, documentation errors and the project forum is “dead”.

Oliot is a fork of the Fosstrak components, which extends GS1 standard architecture to support various IoT connectivity and protocols such as bar code, ZigBee and 6LoWPAN [156]. Inherent to being based on Fosstrak code, it suffers, to certain degree, of the same problems and bugs as Fosstrak services.

Iori Mizutani, in this dissertation [157] and research [158], has contributed with a modern implementation of a F&C middleware (`gosstrak`) and reader emulator (`golemu`) in Golang [159], [160]. His work seems promising in the nonexistent contribution to the EPC-Global standards in the last years. Although, his F&C implementation is not production ready. The project is not actively maintained anymore, only implements a simplified version of the ECSpec and the ALE interface provided is incomplete.

IoTA supplies EPCGlobal tools in their ecosystem of distributed technology [161]. It uses Fosstrak components and adds a prototype of the Discovery Service and secured EPCIS components [162]. Their platform integrates distributed networks, block-chain, micropayments, immutable data and many other technologies which reach far out the scope of this dissertation.

Commercial EPCGlobal solutions are usually not provided as a single product or service. Consulting companies generally provide their services in a solution bundle.

Ricoh commercializes a software middleware F&C solution called RECO-Bridge IDR-1 V2. It sells for 850000 yen ($\approx 6736\text{€}$) and is operated in Microsoft® Windows Server™. Offers

filter capabilities, monitoring functions for RFID systems, provides ALE-complied interfaces, can connect and control up to 32 UHF and/or HF reader/writers ³ and 128 antenna units using LLRP v1.1 protocol interface [163].

Quake Global Inc. commercializes the EasyTap™ RFID middleware [164]. Their web page advertises multiple data services and application integration standards, traffic visualization in real-time and performance optimization capabilities. External sources specify a little further the capabilities of their EasyTAP751 hardware solution seen in figure 5.6. It supports LLRP, provides ALE and EPCIS data capture interfaces [165].



Figure 5.6: Quake Global Inc. EasyTAP751 middleware hardware solution [165]

Transcends commercializes the RIFIDI® Edge Server middleware software solution [166]. It supports LLRP and integrates with most IoT protocols and cloud vendors (e.g. REST, MQTT, JMS, ALE, AWS, Cloud). Does not specify EPCGlobal integration or interfaces. It costs \$3000 in 1st year, \$2000 each consecutive year, per JVM instance up to 10 readers, with 5% price increase for each additional JVM.

5.9 OUR CHOICE

5.9.1 Context

Before proceeding with the discussion on the opted choice of hardware and software, a brief contextualization is needed. The introductory proposal for this dissertation was not clearly defined in terms of objectives and work. The downright agreement was to develop a generic smart shelf solution based on RFID technologies. The application could vary, and was to be used and adapted in a multitude of contexts like lockers and cabinets.

The initial investigation of the literature focused in a set of topics, which would not be directly used in this dissertation. First, it was conducted an exploration of RFID technologies, in order to determine a suitable RF system. It was clear, from early in the study, that UHF RFID would be the most suitable option. The market of UHF had evolved significantly over the years, tags were cheap, performance was better than alternatives and every SCM

³up to 64 if purely using HF reader/writers

deployed was using it. This established confidence in choosing UHF RFID has the technology to integrate in solution.

With the RFID technology determined, I proceeded to study implementation approaches. This prompt research in in UHF antenna design, with attention to manufacturing cost. The fact of smart shelves requiring antennas with specifications fairly distinct from available SCM solutions, fulfilled this research endeavor.

In parallel, an analysis of available readers and requirements was conducted. Readers did not provide sufficient antenna ports to handle the multiple antennas required in most smart shelf designs. For a few application contexts, namely lockers constructed of metal, the poor RF conditions caused by the material, imposed a high number of small antennas. The four antenna ports, provided by most commercial readers, were insufficient. Alternatively, it could be used RF splitters and multiplexers to connect large number of antennas. This alternative was highly expensive.

Later, the exploration of SCM operations and standards, revealed the *EPCGlobal Architecture Framework*. The architecture was extensive, with many details and technicalities, which took a long time to understand and filter for the use case of this dissertation. The inexistent research in developing EPCGlobal compliant products motivated the final proposal of this dissertation.

5.9.2 Implementation Design and Hardware

In the final agreement of this dissertation, it was decided to develop a simple generic smart shelf based on UHF RFID technologies, implementing the necessary EPCGlobal services, standards and interfaces, to achieve a solution where added and removed items could be monitored through a management application. The implementation of the smart shelf had to be simple and cost limited. Due to time constrains, the development of custom hardware had to be avoided in favor of the *EPCGlobal Architecture Framework* implementation.

The shelf used was a $176 \times 160 \times 60$ cmcm MDF and metal construction, shown in figure 5.7. It was chosen for the similarity with most warehouse storage shelves. Was also interest of this dissertation to evaluate real world performance in shelves with metal structures, to study how it interferes with the EMW generated by the reader antenna.

The RFID design solution, chosen for the smart shelf, consists of a single compact antenna and reader attached to the bottom shelf, radiating upwards.

The chosen antenna was a Keonn Advantenna-p14, shown in figure 5.8a. This antenna integrates the same technology group and design as Keonn solution of compact antennas for smart shelves presented in section 4.1.1. The antenna can radiate the entire shelf, with a 30° beam width in the direction of the antenna long edge and 90° in the direction of the antenna short edge, as shown in figure 5.8b.

The reader chosen was the Impinj Speedway R120, shown in figure 5.9. It is a less powerful, 1 antenna port version of the R420 shown in table 5.2. It was chosen for being widely used, has good documentation, tools, state of the art technology, PoE, and most important, provides



Figure 5.7: Leroy Merlin $176 \times 160 \times 60\text{cm}$ MDF and metal construction shelve [167]

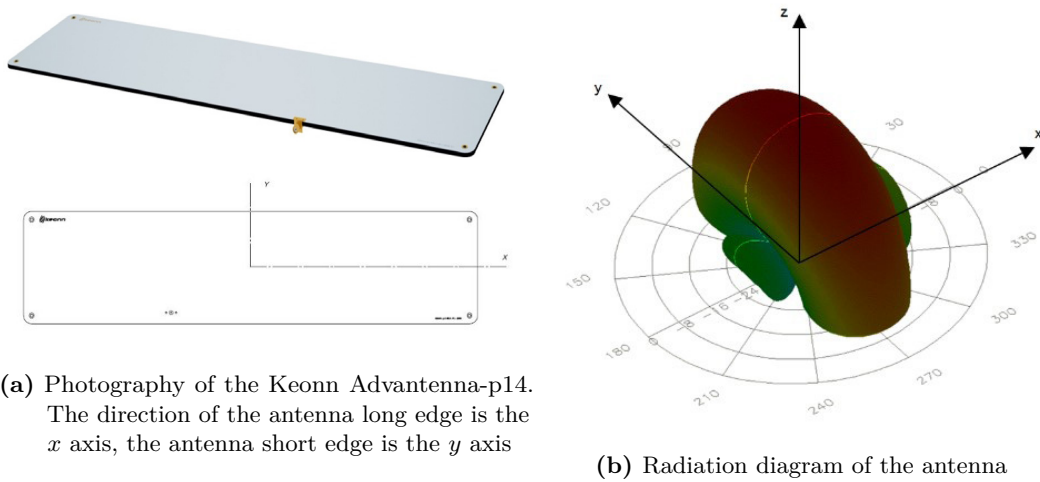

Figure 5.8: Keonn Advantenna-p14 [168]



Figure 5.9: Impinj Speedway R120 reader [170]

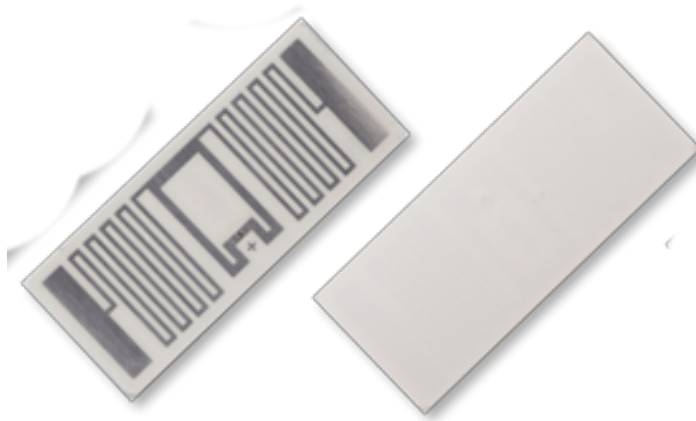

Figure 5.10: HID 6H2E43 92 × 28mm PET tag with 96 bit EPC [172]

an LLRP interface ⁴.

This combination provides very decent performance, without great investment in commercial and custom hardware. Some problems arise from this implementation, mainly with RF obstructions. Performance will be examined in chapter 7.

Regarding tag choices, it is out of the scope of this dissertation. It was used generic HID 6H2E43 tags [171], shown on figure 5.10. These tags use Impinj Monza R6-P chips with 96 bit EPC and 32 bit UMI. They are made of PET material, with a size of 92 × 28mm and reading distance up to 14m.

To program the reader and evaluate its operation, it was used the Octane Java SDK provided by Impinj. The SDK uses the Octane LLRP LTK, as the base library. The Octane LLRP LTK is an extension of the open source LTK implementation, with added Impinj commands, extensions and features. The Octane SDK high level API design captures fairly well the LLRP essence, making it intuitive, with knowledge of the protocol, to understand which LLRP messages are traded and what they contain.

⁴Impinj is one of the big supporter of the LLRP protocol as an open source interface for RFID readers [169]

Regarding the development of the platform, great effort was given to make the EPCGlobal services fairly modular and modern, despite the very old software it runs. Fosstrak Open Source RFID software services were chosen. Alternatives only seemed to complicate and widen the platform with unnecessary features. The problems shown in Fosstrak are also present in the alternatives, which use Fosstrak code. Docker was used to containerize services. Docker packages up code and all its dependencies in what is called a container, which allows applications to run quickly and reliably from one computing environment to another. Docker containers can be easily deployed and managed in all major cloud computing platforms, and are widely used in the current paradigm of cloud computing. Docker compose was used to orchestrate the containers and networks locally for testing.

In the next chapter we will get in to the details of the configuration of the reader and platform services.

System Architecture and Development

In the previous chapter I presented the requirements the solution had to achieve and evaluated different development options, discussing their advantages and disadvantages. I closed the chapter with a solution proposition, where I justified hardware and software choices. In this chapter I will present the implementation details of such solution, going through the architecture design, development considerations and configurations.

6.1 ARCHITECTURE

The architecture used in this dissertation identically follows the EPCGlobal example, presented in figure 3.1 on chapter 3. A detailed overview of the architecture is illustrated in figure 6.1.

The Impinj Speedway R120 reader and Keonn Advantenna-p14 are attached behind the bottom shelf, as shown in figure 6.2, radiating the entire shelf. The reader interrogates the tags, using the EPC UHF Gen2 Air Interface Protocol, following the active ROSpecs configured prior to the inventory. The inventory information is sent inside `RO_ACCESS_REPORT` messages to the LLRP interface of the middleware.

The Fosstrak F&C middleware receives the inventory information from the reader, processes it, following the configured ECSpecs, and periodically generates ECREports, which are sent to the ALE capture interface of the Capture Application.

The Fosstrak Capture Application receives the ECREports, contextualizes them and runs additional business logic. The contextualized data is aggregated in EPCIS event documents, following the CBV vocabulary guidelines, and is sent to the EPCIS repository.

The EPCIS repository permanently saves the EPCIS data into the EPCIS database. The EPCIS repository exposes the SOAP query interface, which can be used to retrieve information.

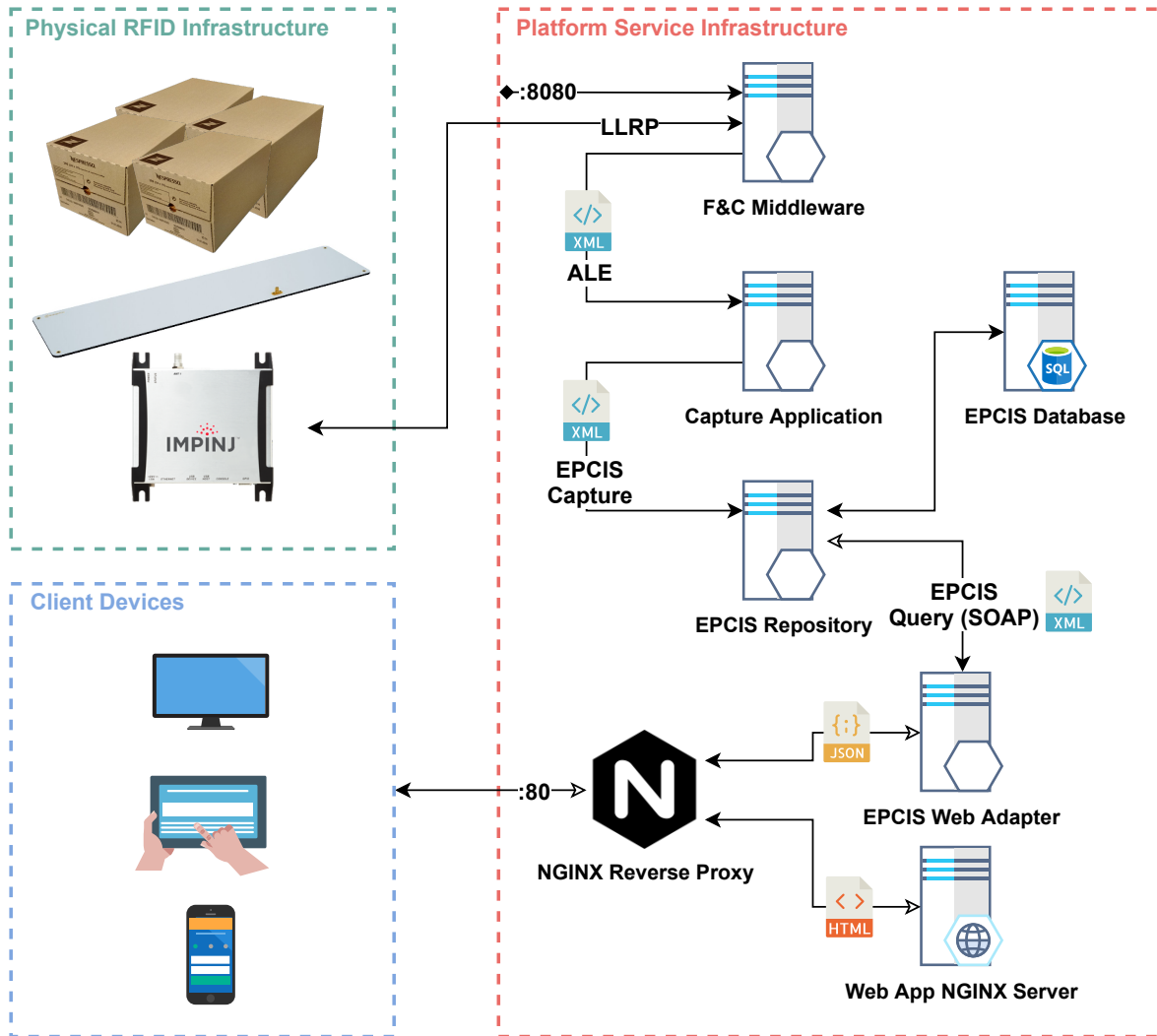

Figure 6.1: Overview of the solution architecture developed in this dissertation



Figure 6.2: Photograph of the Keonn Advantenna-p14 and Impinj Speedway R120 attached behind the bottom shelf

The managing application to visualize the smart shelf inventory, was made using web technologies. The application is served to browsers by an NGINX static file server. The browser running the application queries the data in the EPCIS repository. Modern browsers do not support SOAP natively. To mitigate this problem, the requests pass through a crude EPCIS Web Adapter, serving as proxy between web applications and the EPCIS repository. The proxy converts the SOAP XML requests into HTTP and JavaScript Object Notation (JSON) endpoints, which modern browsers natively support.

All client requests hitting the platform go through an NGINX reverse proxy. This hides the topology and characteristics of the back-end servers, removing the direct internet access to them. The services on the platform are kept inside a non-public subnet and concentrate the access control on that single point. The NGINX server also allows load balancing between services instances, which is useful when there is a need to scale the platform. The proxy also deals with cross-origin resource sharing mechanism, freeing the servers from dealing with it.

All services in the platform infrastructure are containerized using Docker, and orchestrated using Docker Compose. The yaml compose file, containing the description and configuration of the platform services can be consulted in appendix 8.2. All the code, configurations, dockerfiles and other dissertation related code and information can be consulted in the Github repository at <https://github.com/dvcorreia/epc-smart-shelf> [173]. Fosstrak services configurations procedures will not be described in the following sections, as they are documented in their website [174].

6.2 EPC SERIALIZATION PLAN

When companies adhere to the EPCGlobal framework, there are a few things they have to deliberate. One of those is delineating the EPC serialization plan, where an evaluation of unique products and serial numbers is made. The plan has to ensure that a company has enough unique product numbers to identify current and future products.

In the case of this dissertation, the serialization plan was already performed by Nespresso. Each of their products has already an assigned GTIN, including the cardboard cases for transport. The product cardboard cases for transport are identified by GS1-128 barcodes, and sleeves by EAN-13 barcodes. From the EAN-13 barcode in sleeves, the GTIN-13 can be inferred and converted to GTIN-14 for SGTIN-96 encoding on Gen2 EPC RFID tags, which was covered in section 3.4.3. For the GS1-128 barcode in product cases for transport, an example of the barcode deconstruction is illustrated in figure 6.3. From sleeves and boxes used for testing, only two Nespresso company prefixes were present: “76300544” and “76300396” respectively. Nestlé Nespresso SA has many more registered. Searching in GS1 Company Database (GEPiR), it was found 18 more, registered in Switzerland.

With the GTIN-14, it is possible to encode SGTIN-96 in Gen2 tags. To write the EPCs in the testing tags, it was used the Impinj Octane Java SKD `WriteEpc.java` sample code, adapted with the Fosstrak TDT engine. Instead of generating a random EPC, the TDT engine encodes a valid EPC with the correspondent SGTIN - company prefix, item reference and serial - into hexadecimal, which can be passed to the `TagWriteOp` class to configure the

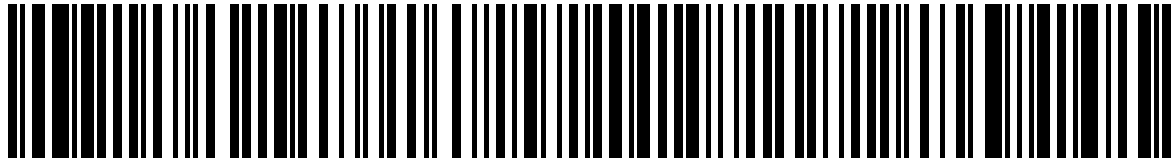

(02)07630054413476(11)200512(15)210531(10)0133378615

GTIN	Production	Best Before	Batch Lote Number
76300544 - Company Prefix	Date	Date	133378615
1347 - Item Reference	12th May 2020	31th May 2021	
6 - Check Digit			

Figure 6.3: Deconstruction of a GS1-128 barcode from a Volluto coffee cardboard case for transport used in this dissertation as a test product (GS1 AI IDs on TDS Section F.1 [52])

reader and program the tag. A tag was attached to each sleeve and transport box, with their correspondent GTIN and unique serial number as a SGTIN-96.

6.3 READER

Throughout this dissertation, the reader was configured employing three approaches: using the Impinj Octane Java SDK [175], the Impinj LTK using XML configuration files [176] and the Fosstrak LLRPComander client software [152]. Each one has their advantages and disadvantages.

In section 3.5 I specified that XML is used to provide a human readability and abstract the LLRP standard. In fact, it can be used to describe LLRP messages like the *ADD_ROSPEC* and *SET_READER_CONFIG*. This makes it easy to create and manage configuration files compared to program code, which requires knowledge of each reader manufactured SDK and referent programming language, to maintain the configurations options.

Reader configuration XML files can be shared between the LLRPCommander and LTK-XML. These configuration methods have a few flaws. From what I experienced, the LLRPCommander has some problems dealing with Impinj extensions and filter parameters, and requires Eclipse 3.3 (2007 build), which is old and not maintained. The Impinj LTK-XML configuration method also seems to have some problems dealing with Impinj extensions¹. The XML parser of the LTK-XML requires fields, ignored Impinj reader in certain conditions, which have to be present in order to validate de XSD schema for the configuration to be validated (e.g *TagInventoryStateAware*, *Tari*).

The approach suggested to configure the reader is using the Octane SDK. It forfeits the advantages of a XML configuration file, but provides all the features expected from the reader, and is reliable and fast to configure. Octane 6.2.0, last version at the time of this dissertation, is based on LLRP version 1.0.1 and does not support some C1G2 v1.2.0 features natively in the LLRP LTK implementation [177]. Octane includes vendor extensions in the SDK to

¹Example: specifying *ImpinjInventorySearchMode* returns unable to convert LTK-XML to Internal Object. *C1G2InventoryCommand* has unknown element *ImpinjInventorySearchMode* which exists and is documented [86]

expose the underlying air protocol features. The reader firmware used was version 5.12.2.240 (Build cbc9ad1d0d1).

The full code used to configure the reader can be consulted in appendix 8.2. The XML configuration files used with LLRPCommander and LTK-XML program can be consulted in appendix 8.2.

In section 3.5.4 I presented the ROSpecs which are used to control the reader operation through the LLRP protocol. The ROSpec defined for this solution will be discussed in detail in this section. Use appendix 8.2 XML configuration files as reference for the following discussions.

6.3.1 Antenna and C1G2 Settings

It is good practice in UHF RFID systems to configure antennas aside from the ROSpec definition. RF antenna parameters are dependent on RFID hardware and environment in which the system is deployed. ROSpecs allow antenna configuration, but should only specify reader control operation, namely inventory logic operations. This ensures configuration interoperability between same logic deployments in disparate RF environments.

Power parameters

To configure the antenna and C1G2 parameters, the LLRP protocol defines the *SET_READER_CONFIG* message. The message contains the *AntennaConfiguration* parameter with a few important fields and parameters:

ReceiverSensitivity specifies the effective receive sensitivity level in dBm. While testing the solution, the RF environment conditions were optimal, as it did not exist interference from other UHF RFID deployments, which allowed setting the reader to the maximum sensitivity of -80 dBm. This sensitivity is index 1 on the *ReceiveSensitivityTableEntry*. For the R120 reader capabilities consult appendix 8.2. *TransmitPower* specifies the transmission power provided to the antennas as an offset into the *TransmitPowerLevelTableEntry*. For the Speedway R120 reader power with PoE, the maximum transmission power is 30 dBm, which is index 81, used in this dissertation for all test [177], [178].

Class 1 Gen2 Settings

The *C1G2InventoryCommand* parameter is where the C1G2 air protocol can be tuned. *TagInventoryStateAware* flag is used to determine how to process all the *C1G2Filter* and *C1G2Singulation* parameters in this command ².

The *C1G2RFControl* parameter specifies Speedway Gen2 modes selected by Impinj system engineering to provide the best RF performance in different environments. No Tari adjustment is necessary and any value passed by the client will be ignored in favor of Impinj mode value [177]. *ModeIndex* selects the operation mode [177], [179]. For the use case of this

²At a functional level, if the Client is managing the tag states during an inventory operation (i.e the Client is specifying C1G2 tag Select command Target and Action values), then it will set that flag to true and pass the appropriate fields in the C1G2 Filter and C1G2 Singulation parameters. If a reader sets *CanDoTagInventoryStateAwareSingulation* to False in *LLRPCapabilities*, then the Reader shall ignore the *TagInventoryStateAware* flag [54]

dissertation, it can be one of the three bellow, depending on the RF environment in which the system is deployed:

- “1002” (AutoSet Dense Reader Deep Scan) configures the Reader to choose the best Gen2 link parameters for the environments where the tag population is relatively static and we wish to attempt to search for the weakest tag [180];
- “1003” (Autoset Static Fast) is an adaptation of Autoset Dense Reader Deep Scan for good RF environments;
- “1004” (AutoSet Static Dense Reader) is an adaptation of Autoset Dense Reader Deep Scan for difficult RF environments.

The option used in this dissertation was `ModeIndex` “1002”. The “1004” is not currently available for the R120 in the ETSI european UHF band. The “1003” does not provide assurance in warehouse malls, where other readers systems can operate and create poor RF environment conditions.

Singulation Configuration

Impinj offers a few custom parameters supported in Octane LLRP vendor extensions, namely the `ImpinjInventorySearchMode`, a Impinj-specific inventory search mode. To understand search modes, we have to understand sessions. This thematic goes deep in to the C1G2 air protocol and will only be briefly contextualized. Gen2 defines up to four tag sessions. Sessions are states tags can transit to, in order to help the reader attempt to singulate, i.g read, each tag in the inventory. When many tags are read at the same time, tag-to-tag interference can prevent certain tags to be read properly. Sessions can be used to determine when a tag will respond to a query from the reader, and/or allow tags to maintain independent states when communicating with multiple readers at the same time. As an example, a reader can query tags in state “A”. If tags are properly read by the reader, they transit to state “B”. The reader follows with another query of tags in state “A”. Tags which were not previously read due to tag-to-tag interference, have not better RF environment conditions to do so.

Impinj readers implement state unaware singulation, in that they provide a high-level control over the search algorithm, through `ImpinjInventorySearchMode` parameter, not interfering with any of the standard LLRP/Gen2 settings [177], [181]. Impinj search modes can be consulted in appendix 8.2. In this dissertation we used Tag Focus to make sure every tag was read. This was possible only because we used HID 6H2E43 tags with use Monza chips in this dissertation. For generic tags I recommend using Dual Target Inventory search mode. These algorithms will be described further in this dissertation.

Using purely LLRP settings configuration, for interchangeability with other reader manufacturers, Gen2 provides the `C1G2SingulationControl` parameter to command the singulation process in the C1G2 air protocol:

- `TagTransitTime` is the measure of expected tag mobility in the field of view of the antenna where this inventory operation is getting executed.
- `TagPopulation` is the expected tag population in the field of view of the antenna.

- Session ID is the C1G2 session number that the tags use to update the inventory state upon successful singulation.
- `TagInventoryStateAwareSingulationAction` is used if the `TagInventoryStateAware` flag is set to true in the `InventoryParameterSpec`. It is used to query, select and deselect target tag population in a selected session.

Configurations with tuning of these settings were done for testing, but were not used in the final prototype presented in this dissertation, so no further configuration details will be done.

Gen2 EPC Filtering

In the LLRP and LTK-XML configurations I could not make it work, but with the Java Octane reader configuration, it was possible to implement EPC filtering directly through the C1G2 protocol.

The filtering works by defining filter parameters, which are sent in the air protocol, in the query process, for tags to evaluate if they correspond to the desired population to be inventoried. Only tags corresponding to such filter specifications answer back. The C1G2 filter can be used to match any Gen2 tag memory data, not EPC exclusively. Air protocol filtering greatly reduces tag-to-tag interference, decreases RF environment noise, lowers traffic in the network infrastructure and removes filtering work otherwise accomplished by the middleware.

The C1G2 protocol provides three parameters which can be used to specify the filter:

- `BitPointer` (integer): corresponds to the start bit position to apply the tag mask when performing tag filtering;
- `BitCount` (integer): defines the number of bits to compare against the mask;
- `mask`: is the mask to be compared. It must be of a bit length divisible by 8, being usually represented in hexadecimal [54].

In figure 6.4 can be observed a deduction of the parameters presented previously for an EPC example extracted from the platform. To match both company prefixes found in the test products, the bit pointer should point to the first bit of the company prefix EPC memory, which will be the pointer to the EPC memory bank plus 14 bits. The bit count should be the size of the company prefix, 27 bits. The mask has to be at least 32 bits, which for company prefix of “76300544” the mask can be 91882001 and for “76300396” can be 91880D82.

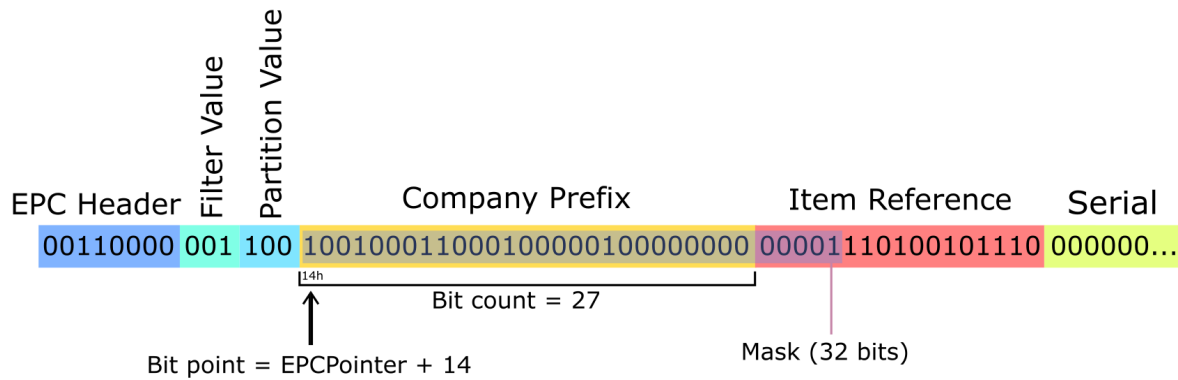

Figure 6.4: Illustration of company prefix C1G2 filtering parameter deduction

6.3.2 Operation Configuration

With the antenna and Gen2 protocol configured, we can focus on the operations the reader has to perform on the tag population. In this dissertation we want to perform an inventory of the products stored in the shelf. Reader inventory operations are described in ROSpecs. In section 3.5.4, I described the parameters composing an ROSpec document, particularly, the `ROBoundarySpec`, `AISpec` and `ROReportSpec` which will be discussed next.

ROBoundarySpec

The `ROBoundarySpec` parameter describes the lifetime of the reader inventory and survey operations. The lifetime can be configured in different ways, with no clear preferable method. The RFID integrator engineers have to evaluate a sensible and effective Spec to met the requirements of the project at hands.

In designing this Spec, the configurations made previously to the antenna and C1G2 protocol should be accounted, namely the search singulation algorithm mode. For the Tag Focus search mode, the reader inventories tags in state “A”, transitioning the tags to state “B” upon singulation. Tags transition back to state “A” in less than 5 seconds, when de-energized [177]. Dual Target search mode inventories tags in state “A”, transitioning the tags to state “B”. Then inventories tags in state “B”, transitioning the tags back to state “A”. Evaluating both search modes, the solution used consisted in periodically inventor the tags, every 5 seconds with a 2 seconds inventory time [177], [181]. This allowed a full Tag Focus search inventory search cycle while providing enough time for the Dual Target search mode.

Translating the lifetime plan to the Spec parameters, the `ROBoundarySpec` parameter should look like code 7. The `ROSpecStartTrigger` should be periodic, with a period of 5000 milliseconds, and no offset. The `ROSpecStopTrigger` triggers 2000 milliseconds after receiving the trigger to start the ROSpec, effectively stopping the ROSpec. These values can be changed to match the requirements of shelf clients.

```

1      <ROBoundarySpec>
2      <ROSpecStartTrigger>
3      <ROSpecStartTriggerType>Periodic<ROSpecStartTriggerType>
4      <PeriodicTriggerValue>
5      <Offset>0</Offset>
6      <Period>5000</Period>
7      </PeriodicTriggerValue>
8      </ROSpecStartTrigger>
9      <ROSpecStopTrigger>
10     <ROSpecStopTriggerType>Duration<ROSpecStopTriggerType>
11     <DurationTriggerValue>2000</DurationTriggerValue>
12     </ROSpecStopTrigger>
13 </ROBoundarySpec>

```

Código 7

Antenna Inventory Spec

For the AISpec parameters, most of the configuration were already done through the *SET_READER_CONFIG* message, presented in the previous section.

Although, it is necessary to specify, in the XML configuration files, the RFID air protocol, namely EPCGlobalClass1Gen2, inside the *InventoryParameterSpec*. The *AISpecStopTrigger* parameter defines the terminating boundary of an antenna inventory operation, which was set to Null to stop when ROSpec is terminated [54].

Report Operation Report Spec (ROReportSpec)

The *ROReportSpec* parameter describes the messages and parameters used in reports, event notifications and keepalives that are generated by the Reader and sent to the Client.

Important to consider, evaluating RFID event based systems, is when reports are generated and sent to the Client. In the use case of this dissertation we are not concerned with near real-time updates on the state of the inventory. We are more interested in the networking infrastructure health in which the system is deployed. In mall warehouses, this infrastructure is most likely shared with other companies. Traffic generated by readers needs to be controlled to not overburden the network infrastructure.

With this in mind, the report generation is triggered by the end of the ROSpec. This will generate a report periodically every 5 seconds. For this behavior *ROReportTrigger* should be set to *Upon_N_Tags_Or_End_Of_ROSpec* with $N = 0$, meaning unlimited tag in the field of view of the antenna, as it can be set to send a report upon singulation of N tags [54].

The *ROReportSpec* also selects which content of each report sent to the client includes. The EPC is always delivered by default. In terms of the content useful to retrieve from the reader inventory singulation, the *ROSpecID*, *FirstSeenTimestamp* and *LastSeenTimestamp* are in the interests of the application. This content allows the middleware to generate accurate tag timestamp information without real-time report delivery.

6.4 F&C MIDDLEWARE

To configure the Fosstrak F&C middleware we need to define LRSpecs and ECSpecs. LRSpecs identifies the reader, its IP address, port number and type, which is required for abstraction layers used with proprietary communication interfaces in some readers. The LRSpecs for the Impinj Speedway R120 reader, using the LLRP interface, was already presented in the state of the art as an example, which can be seen in code 2.

Following the requirements of the solution, the configuration of the ECSpec has to provide two ECRports to the capture application: one informing the tag URIs added to the shelf and another informing tag URIs removed from the shelf. The ECSpec can also be seen in state of the art in code 3. Every 5 seconds, the middleware will report to the capture application added and removed tag URIs. This configuration can be as complex as the RFID integrator engineer seems fit for the solution at hands. Since EPC filtering was achieved through the C1G2 protocol, no filtering was required in the middleware. For an example of what a more complex shelf middleware configuration for this application would look like, I defined a ECSpec which can be consulted in appendix 8.2.

6.5 CAPTURE APPLICATION

The Fosstrak Capture application allows the definition of business logic through the Drools engine, a Java business rules management system. For the requirements of this solutions, it were defined two rules: one for added items and another for removed items. Each generates a single EPCIS ObjectEvent document following CBV documents and guidelines [58]. The ObjectEvent contains:

- **EPC List:** containing a list of tag URIs.
- **Action type:** OBSERVED.
- **Event time:** ISO 8601 generated automatically by the capture application software.
- **Event Time Zone Offset:** ISO 8601 generated automatically by the capture application software.
- **Read Point:** “urn:epc:id:sgln:76300544.00000.1”, a fictitious read point created for test purposes. It identifies the shelf within the business location.
- **Business Location:** “urn:epc:id:sgln:76300544.00000.0”, a fictitious business location created for test purposes. Identifies the Nespresso boutique store in Aveiro.
- **Business Step:**
 - For added items “urn:epcglobal:cbv:bizstep:storing”: denotes a business process where an object is moved into and out of storage within a location.
 - For removed items “urn:epcglobal:cbv:bizstep:unpacking”: denotes a business process that includes removing products (individuals, inners, cases, pallets) from a larger container (it is not the best description of the event, but the most similar provided in the CBV).
- **Disposition:**

- For added items “urn:epcglobal:cbv:disp:sellable_not_accessible”: product can be sold as is, but customer cannot access product for purchase.
- For removed items “urn:epcglobal:cbv:disp:partially_dispensed”: a portion of a product is distributed to a customer, while additional product is retained for subsequent distribution.

The capture application, in a real world context, could implement much more complex business logic: provide information to other inventory data services, process data, and present better context regarding the CBV.

6.6 EPCIS REPOSITORY AND ADAPTER

The EPCIS repository does not require any configuration except for containerizing the service and provide a SQL database instance configured with the EPCIS schema and user privileges.

To facilitate the interaction with the EPCIS repository by modern web browsers, the EPCIS Adapter service was developed with the Go programming language. There is an available EPCIS Webadapter by the Fosstrak team [182], but I could not get it to work. The service implements a crude and partial adaption of the EPCIS SOAP Query Interface. A functional block illustration of the service can be seen in figure 6.5. It implements endpoints for the SOAP `poll SimpleEventQuery` and `subscribe` operations through the `/query/location` and `/ws` endpoints respectively.

For the `poll` operation, the service translates HTTP queries into SOAP envelopes, which are sent to the EPCIS repository. Response data is translated from XML into JSON, and sent back to the web client. For the `subscribe` operation, the subscription endpoint converts the query into SOAP and registers the subscription in the EPCIS repository ³. The event data is sent by the EPCIS repository to the root endpoint of the adapter, were is delivered in JSON to the client, using websockets in the `/ws` HTTP upgraded endpoint connection. The EPCIS data model used to convert XML into JSON and JSON intoXML can be seen in appendix 8.2. The full service code can be consulted in the dissertation Github repository [173].

³The `/subscribe` endpoint exists but it not implemented. Tests with manual set of subscriptions used to test the websockets proxy showed some bugs regarding subscription event delivery, whereby dropped and not implemented. The service proxy implementation can still receive subscription data event and deliver them using websockets, being to the client to register the subscription directly with the EPCIS repository.



Figure 6.5: Functional block illustration with endpoints of the EPCIS-adapter developed in this dissertation

6.7 MANAGEMENT APPLICATION

The development of the management application is out of the scope of this dissertation, but will be briefly contextualized.

The application was developed for browsers as a web application. This enables most modern internet browser capable devices to use it. It was implemented using ReactJS [183], a JavaScript library for building user interfaces, with Ant Design UI components [184]. The web application is compiled and minified into static web files which are served by an NGINX static file server instance. A picture of the management application can be seen in figure 6.6.

The application shows the date and time of the event, the EPC serial numbers, the coffee name and a count of those items. If the item is a trading box for transportation it shows a “box” icon next to the coffee name. The application implements only the logic required to show in real-time the inventory information. Disable buttons are provided to show a contextualization of what the full fledge management application would look like.

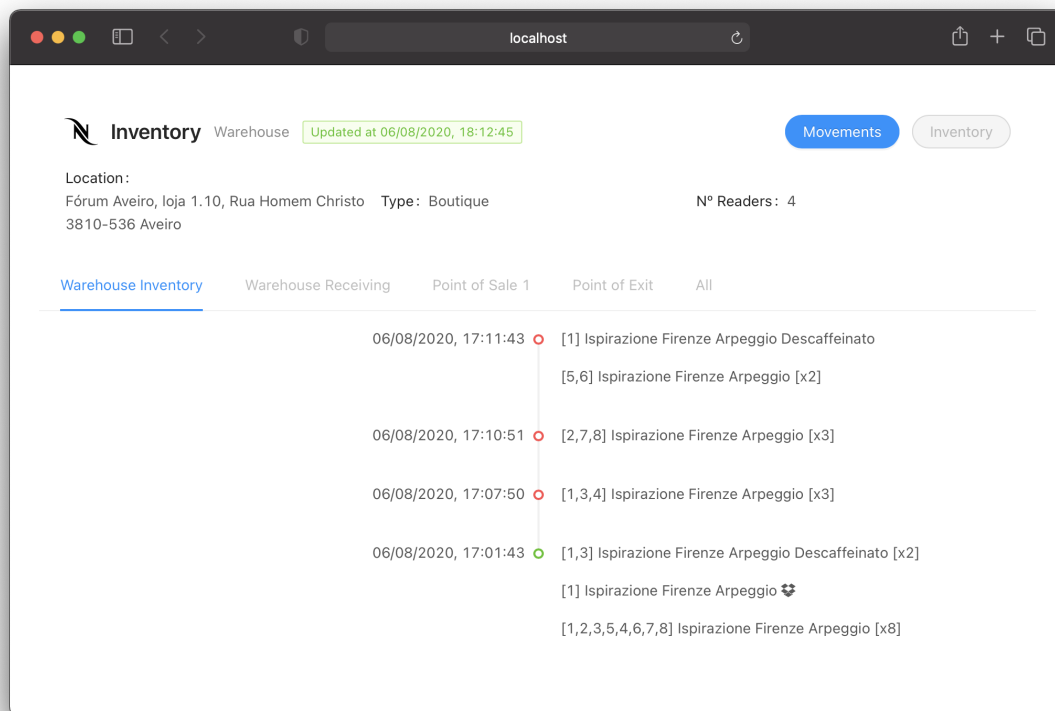

Figure 6.6: Web management application interface running on the OSX Safari browser

Test and Evaluation

The conceptualization of the tests focused in evaluating how well the solution performs with the constraints made in the hardware and software choices. It aims at testing the RF solution performance and validate the platform data flow from tag to client. The moment the final design of the smart shelf was settled, it was evident that two problems could compromise the performance of the solution: the metal structure of the shelf and the old, not maintained, Fosstrak open-source software.

In this chapter will be presented a few tests designed to hint and show how these problems compromise the solution. Throughout the tests, the tags were attached to empty sleeves and boxes, representing an ideal test environment with no RF quality compromising materials¹. The reader configuration used for the tests maintains the same power transmission ($30dBm$) and sensibility ($-80dBm$) configurations.

7.1 TAG ORIENTATION

Prior to the implementation of the final solution, an RF analysis of tag orientation in the shelf was conducted. The objective was to evaluate the optimal tag orientation in stored products, and provide an idea of system reading performance early in the development. Tags were tested in three different orientations, illustrated in figure 7.1.

This test was executed solely on the bottom shelf, since the results could be inferred to the others. The bottom shelf also presented the major apparent challenges: it had to operate in the *near-field* and was too close to the antenna, which could cause miss readings in the outer laterals due to the beam width not being wide enough.

The test was conducted by dividing the bottom shelf into 18 quadrants ($26.6 \times 20cm$ quadrants) and measure RSSI values, referent to a single tag, within those quadrants, with a transmission power of $30dBm$ and maximum sensitivity of $-80dBm$. The RSSI results are a

¹It was not possible to attain sleeves with aluminum capsules for testing. They would certainly interfere with the following test results, but not accounted in the work of this dissertation.



Figure 7.1: Tag orientation tested in this dissertation: horizontal, lateral and vertical, respectively

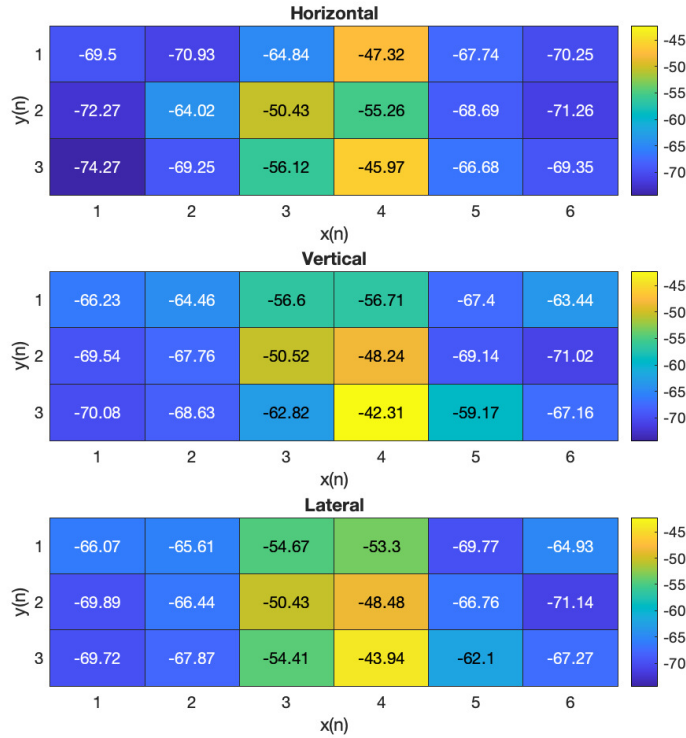

Figure 7.2: RSSI reading results for the different considered tag orientations in dBm

mean value calculated from 1000 values sampled from each quadrant in a uniform motion across the area, repeated in same manner for each quadrant.

The results are shown in figure 7.2 in heatmap plots. They do not represent the obstructions spread across the shelf. These obstructions prevent tag readings, which were not accounted in this test. Obstructions will be evaluated in the next test.

From the results obtained, there was no clear superior orientation. The circular Keonn Advantenna-p14 in conjunction with the RF signal deformations caused by the metal structure, make a good job in providing orientation independence.

A few peculiar observations from the tests were observed and are described next:

- Horizontal orientated tags have reading problems near the shelf outside metal structure;
- Vertical orientated tags, in contrast with horizontal orientated ones, have better reading values near the shelf outside metal structure. They present problems placed on top of

the metal bars used to support the shelves.

- Lateral orientated tags present reading difficulty when placed on top of the support metal bars and really close to conners.

No major benefits were presented by any orientation. Theoretically, the lateral tag orientation would present most problems, being parallel to the axis of the EMWs propagation. In order to test the system in the most extreme conditions, the lateral orientation was used for sleeves throughout the dissertation and horizontal orientation for product cases for transport.

7.2 SHELF RF SURVEY

The objective of this test was to study and evaluate the certainty and quality of tag readings, by making an RF survey of the shelf, with the lateral tag orientation defined previously. It aims at evaluating the RF obstructions present in the solution, which were not considered in the first test. The results should offer a good representation of the RF environment in the shelf and what it could be expected from tag readings in certain locations. From the previous test, it was observed that the RSSI does not change in time when a single tag is placed in one specific location, allowing the sampling of a single RSSI value per location.

The test consisted, once again, in dividing the shelves into quadrants and measure RSSI values within those quadrants. This time, each shelf was divided in 140 quadrants (20×7 grid, $8 \times 8.6\text{cm}$ quadrants) to have a better perspective of RF obstructions. Measurements were also taken in between shelves. The transmission power and sensitivity were maintained from the previous test. The results can be seen in figure 7.3.

It is possible to observe the obstructions caused from the metal bars used to support the middle of each shelf. The surrounding metal structure does not seem to interfere significantly

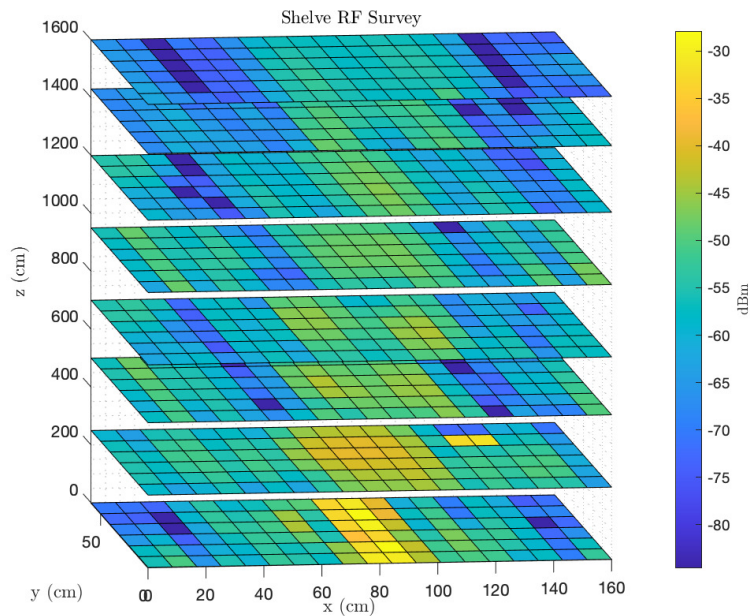

Figure 7.3: Shelf RF survey showing the RSSI values within the 20×7 grid

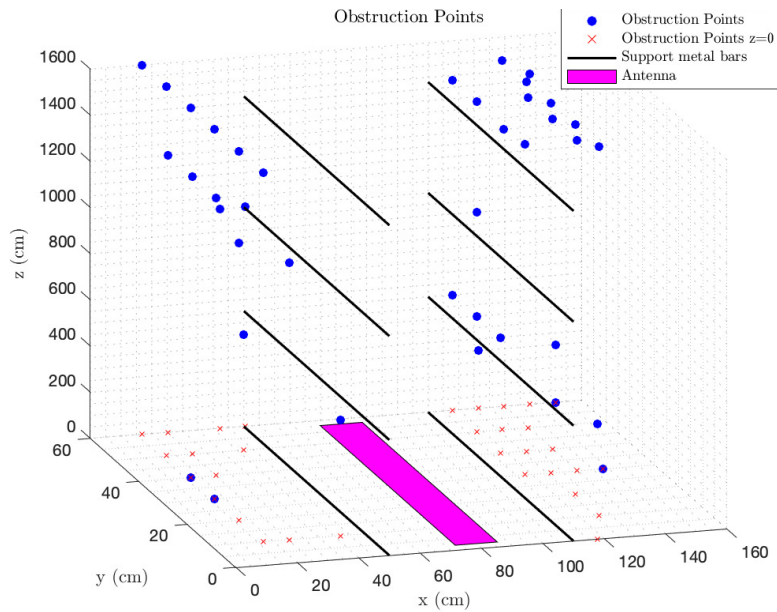

Figure 7.4: RF survey obstructions points shown in conjunction with support metal bars and antenna placement

to the point of tag blocking readings. We can also observe poor RSSI values near the first shelf, as observed in previous test with lateral orientated tags. To have a better perspective on obstruction points across the shelves, in relation to the support metal bars and antenna placement, a graph with those illustrated is shown in figure 7.4.

7.3 SINGULATION STRESS TEST

This test aimed at complementing the observations from previous test by evaluating how the obstructions affect readings of a group of tags placed on top RF “blind” quadrants. The test method consisted of selecting locations where obstructions were prevalent and for each one, at a time, place boxes full of sleeves in those positions to evaluate for miss readings.

From this test it was possible to retrieve some interesting observations. As expected, RF obstructions cause miss readings, but the phenomenon is not as linear as the previous tests, which used a single tag. Some obstruction locations did not present miss readings. In those locations, when a sleeve was removed from the case for transport, a tag would miss read, as illustrated in figure 7.5. The “disappearing” tag could be right next to the removed one or in other box, not being evident the obstruction phenomenon happening. The phenomenon can be linked to:

- RF obstructions resulting from the presence of RF-opaque or RF-absorbent objects which block and absorb RF waves respectively [15];
- “Re-radiating” phenomenon due to the *near-field* Fresnel region reacting with the metal structure and the tags antennas themselves [17];
- Tag-to-tag interference.



Figure 7.5: Non linear obstruction phenomenon illustrating miss readings caused by the removal of a tagged sleeve

More research and tests have to be performed in order to confirm these hypotheses. To complement the observations in these tests, a few metal objects were placed on the shelf, namely an aluminum notebook computer, an aluminum window frame, and a steel oil heater placed near the shelf. The aluminum notebook and window placed in different locations, would interfere with the tag readings. The steel oil heater placed leaning on the shelf did not seem to interfere in any way, indicating a good and confined shelf RF radiation.

7.4 OPERATIONAL TEST

For the final test, the objective is to validate the platform operation. The test consisted of making inventory changes and validating through the web management application and database entries if the data is in accordance with those changes, namely if tags added and removed are adequately identified.

The platform was able to adequately read the inventory changes, publish them to the EPCIS repository and be visualized in the web management application.

7.4.1 Problems

Some problems of the software platform were already hinted throughout this dissertation, namely in section 5.8.2. The Fosstrak software components used in this dissertation are not maintained. The problems caused by bugs, confusion in outdated documentation and runtime errors were the issues that took most working hours in this dissertation, many which could not be solved. Modern Java and Tomcat versions created breaking changes in the code, which forced the use of old versions. These old versions also did not solve all the problems, but reduced the amount of bugs to a point where the platform was working. A few major problems presented in the final platform solution will be described next.

Starting with the F&C middleware, it presents multiple problems. The web-based client is broken. The static logical reader definitions are broken. The standalone client works, but when registering LRSpecs and ECSpecs, most of the times, causes the server to break due to concurrent modification thread errors.

The capture application also presents a few problems. The connection between the ALE interface of the capture application and the middleware seems to have some issues. Using the middleware log information, it is possible to verify that the middleware processes the reports delivered by the reader, but they are not received or processed by the capture application. Further inspection on the capture application can not be done due to inexistent log files of the service. The Drools engine used by the capture application is also old with complex mechanism. Development of complex business logic was a challenge, even with support of experienced Drools users.

Regarding the EPCIS repository, the subscriptions drop EPCIS data for no apparent reason, requests are delivered in random time frames and there are problems fetching them from the current active subscriptions. The EPCIS database also has some problems with modern versions of the MySQL image.

These were the issues present in the final build of the platform. The most time consuming, by far, in this dissertation, was to fix these type of problems, changing Java and Tomcat versions, docker images, containerization configurations, analyzing log files, configurations, to say a few.

Conclusion and Future Work

This work presented the development of a smart shelf based on UHF RFID technology, intended to be deployed in stock rooms and warehouses, which follows GS1's EPCGlobal group of technologies, protocols and standards, to seemly integrate in global supply chain systems deployed around the globe.

The advance of cloud computing, IoT and *Industry 4.0* encouraged the supply chain and logistics industries to digitize their operations and further optimise their resources. UHF RFID provided the tools to wirelessly identify physical objects, like products and assets, which, in cooperation with the *EPCGlobal Architecture Framework*, allowed the identification of every item anywhere in the world and share of strategic logistic information, automatically and consistently between trading partners, to empower production and distribution across businesses.

The dissertation started by outlining important aspects regarding RFID technologies and the *EPCGlobal Architecture Framework*. It followed by discussing and presenting multiple hardware architectural designs, R&D resources required to implement those and evaluating each development option in regard to costs and time.

The discussion was followed by the development of a prototype, employing commercial hardware and a generic warehouse shelf, in a design devised to alleviate cost. The hardware was connected to a platform of services orchestrated to operate in modern cloud deployments, using the current paradigm of service containerization. The platform uses Fosstrak components for EPCGlobal services, namely F&C Middleware, Capture Application and EPCIS Repository. To meet the requirements of the product, it was implemented a custom EPCIS Adapter and a web management application to visualize inventory changes.

The RFID hardware solution was tested for performance, evaluating tag optimal orientation, performing an RF survey in different zones of the shelf and a stress of testing poor RF condition zones. The shelf showed limited effect on RF communications thus not confirming the initial assessment of problems it could present. The platform was also tested for validation of operation and data consistency.

8.1 MAIN ACHIEVEMENTS

Based on these facts, it is possible to affirm that the objectives of this dissertation were met. The smart shelf was capable of correctly identifying added and removed products, and publishing those events using EPCGlobal technologies, to a platform capable of integrate most SCM systems around the globe.

The dissertation not only shows the development of this shelf, but also a rationalization of different approaches and options regarding the development of UHF RFID-based smart shelves, which can be consulted for further investigation by companies and researchers interested in pursuing such endeavor.

From what I could find, it might be the first dissertation of this kind, in that the *EPCGlobal Architecture Framework* was directly applied to a product from hardware to user application, implementing all the stack of services required of a functional EPC-enabled product.

8.2 FUTURE WORK

The smart shelf solution is far from being a commercial viable solution. Future tasks regarding the improvement of the solution:

- Amend the RF coverage in the shelf by reducing obstruction locations: use shelves without support metal bars, employ a second antenna, improve the RF design or even design custom antennas;
- Fix bugs on the Fosstrak services or implement modern solutions for the EPCGlobal technologies. Tune the platform and add mechanisms for high horizontal scalability;
- Finish the implementation of the EPCIS Adapter and enhance the management application logic and features (e.g automatic request of new stock, warnings on low product stock, sessions for users, to say a few);
- Design a “smart reader” for shelf systems, encompassing C1G2 reader capabilities, F&C middleware and capture application in one hardware solution;
- Add features to the shelf system: better contextualization of EPC data and improved capture application business logic.

Referências

- [1] *Oxford Languages and Google - English -*, es-ES, <https://languages.oup.com/google-dictionary-en/>.
- [2] B. Marr, *What Is Industry 4.0? Here's A Super Easy Explanation For Anyone*, en, <https://www.forbes.com/sites/bernardmarr/2018/09/02/what-is-industry-4-0-heres-a-super-easy-explanation-for-anyone/>.
- [3] B. C. Hardgrave and J. Patton, «2016 State of RFID Adoption Among U.S. Apparel Retailers», en, p. 7,
- [4] *DOD Releases Final RFID Policy - 2004-08-09 - Page 1 - RFID Journal*, <https://www.rfidjournal.com/articles/view?1080>.
- [5] V. Oana, Barna, C. Maria, I. Surugiu, R. Petrescu, and V. Alexandrescu, «RFID Technology in Containers Multimodal Transport», *Supply Chain Management Journal*, vol. 4, Jan. 2013.
- [6] D. M. Dobkin, *The RF in RFID, Second Edition: UHF RFID in Practice*, Second. USA: Newnes, 2012, ISBN: 0-12-394583-6.
- [7] *The History of RFID Technology | RFID JOURNAL*, <https://www.rfidjournal.com/the-history-of-rfid-technology>.
- [8] André Ventura da Cruz Marnoto Zúquete and N. Borges de Carvalho, *Identificação Por RFID, 2017-2018, Slides*, English, Universidade de Aveiro, 2018.
- [9] J. Landt, «The History of RFID», *IEEE Potentials*, vol. 24, no. 4, pp. 8–11, 2005.
- [10] H. Casier, M. Steyaert, and A. Roermund, van, Eds., *Analog Circuit Design : Robust Design, Sigma Delta Converters, RFID*, English. Germany: Springer, 2011, ISBN: 978-94-007-0390-2. DOI: 10.1007/978-94-007-0391-9.
- [11] *RFID Adoption Stalls: Executive Summary | Computer Economics – for IT Metrics, Ratios, Benchmarks, and Research Advisories for IT Management*, <https://www.computereconomics.com/article.cfm?id=1203>.
- [12] S. Gaudin, *Some Suppliers Gain from Failed Wal-Mart RFID Edict*, en, <https://www.cio.com/article/2436434/some-suppliers-gain-from-failed-wal-mart-rfid-edict.html>, Apr. 2008.
- [13] *RFID in Retail Apparel*, en-US, <https://gaorfid.com/rfid-in-retail-apparel/>.
- [14] K. Finkenzerler, *RFID Handbook: Fundamentals and Applications in Contactless Smart Cards and Identification*, Second. Wiley Publishing, 2003, ISBN: 0-470-84402-7.
- [15] S. Lahiri, *RFID Sourcebook*. IBM Press, 2005, ISBN: 0-13-185137-3.
- [16] C. A. Balanis, *Antenna Theory: Analysis and Design*. Wiley-Interscience, 2005.
- [17] *Electromagnetic Radiation: Field Memo | Occupational Safety and Health Administration*, <https://www.osha.gov/radiofrequency-and-microwave-radiation/electromagnetic-field-memo>.
- [18] Zerodamage and Peter R. Franchi et al., *Far and Near Fields (Vectorized)*, en, Mar. 1991.
- [19] P. Nikitin, K. Rao, and S. Lazar, «An Overview of near Field UHF RFID», ser. IEEE Int Conf RFID, Apr. 2007, pp. 167–174. DOI: 10.1109/RFID.2007.346165.

- [20] *Safety and Health Topics / Radiofrequency and Microwave Radiation - Electromagnetic Radiation: Field Memo / Occupational Safety and Health Administration*, https://www.osha.gov/SLTC/radiofrequencyradiation/electromagnetic_fieldmemo/electromagnetic.html.
- [21] *Impinj M730 & M750 Product Brief / Datasheet*, en-US, <http://support.impinj.com/hc/en-us/articles/360010797539>.
- [22] Alien, *Alien Product Family Overview (2020 06 29)*, Jun. 2020.
- [23] H. Tsai, K. Chen, Y. Liu, J. Norair, S. Bellamy, and J. Shuler, «Applying RFID Technology in Nuclear Materials Management», *Packaging, Transport, Storage and Security of Radioactive Material*, vol. 19, Mar. 2008. DOI: 10.1179/174651008X279000.
- [24] Caen, *Caen A927Z Temp Logger Data Sheet 2018*.
- [25] *RFID Coupling Techniques: Backscatter Capacitive Inductive » Electronics Notes*, <https://www.electronics-notes.com/articles/connectivity/rfid-radio-frequency-identification/coupling-techniques-capacitive-inductive-backscatter.php>.
- [26] ISO, *ISO 11784:1996*, en, <https://www.iso.org/cms/render/live/en/sites/isoorg/contents/data/standard/02/58/25881.html>.
- [27] —, *ISO 11785:1996*, en, <https://www.iso.org/cms/render/live/en/sites/isoorg/contents/data/standard/01/99/19982.html>.
- [28] —, *ISO 14223-3:2018*, en, <https://www.iso.org/cms/render/live/en/sites/isoorg/contents/data/standard/05/96/59602.html>.
- [29] —, *ISO/IEC 18000-2:2009*, en, <https://www.iso.org/cms/render/live/en/sites/isoorg/contents/data/standard/04/61/46146.html>.
- [30] —, *ISO/IEC 15693-2:2019*, en, <https://www.iso.org/cms/render/live/en/sites/isoorg/contents/data/standard/07/36/73601.html>.
- [31] *MIFARE*, <https://www.mifare.net/en/>.
- [32] —, *ISO/IEC 14443-4:2018*, en, <https://www.iso.org/cms/render/live/en/sites/isoorg/contents/data/standard/07/35/73599.html>.
- [33] —, *ISO/IEC 18000-3:2010*, en, <https://www.iso.org/cms/render/live/en/sites/isoorg/contents/data/standard/05/34/53424.html>.
- [34] —, *ISO/IEC 18000-7:2014*, en, <https://www.iso.org/cms/render/live/en/sites/isoorg/contents/data/standard/05/73/57336.html>.
- [35] —, *ISO/IEC 18000-6:2010*, en, <https://www.iso.org/cms/render/live/en/sites/isoorg/contents/data/standard/04/61/46149.html>.
- [36] —, *ISO/IEC 18000-4:2015*, en, <https://www.iso.org/cms/render/live/en/sites/isoorg/contents/data/standard/06/25/62539.html>.
- [37] Hugo Manuel Oliveira de Miranda, «Sistemas RFID UHF», pt-PT, MSc Dissertation, Universidade de Aveiro, Aveiro, 2015.
- [38] M. Lorenz, J. Müller, M.-P. Schapranow, P. D. A. Zeier, and H. Plattner, «Discovery Services in the EPC Network», in, Jun. 2011, ISBN: 978-953-307-265-4. DOI: 10.5772/16658.
- [39] D. Simchi-Levi, P. Kaminsky, and E. Simchi-Levi, *Cadeias de Suprimentos Projeto e Gestao*. Bookman, 2003, ISBN: 978-85-363-0119-8.
- [40] Anonymous, *Standards / GS1*, en, <https://www.gs1.org/standards>, Text, Dec. 2014.
- [41] *DoD_Suppliers_Passive_RFID_Info_Guide_v15update.Pdf*, https://www.acq.osd.mil/log/SCI/.AIT.html/DoD_Suppliers_Passive_RFID_Info_Guide_v15update.pdf.
- [42] *What Is RAIN RFID Technology? | IMPINJ*, <https://www.impinj.com/about-rfid/about-rfid>.

- [43] *Technology Companies Create RAIN to Promote EPC UHF RFID Adoption - 2014-04-09 - Page 1 - RFID Journal*, <https://www.rfidjournal.com/articles/view?11665>.
- [44] *En_302208v030101p.Pdf*, https://www.etsi.org/deliver/etsi_en/302200_302299/302208/03.01.01_60/en_302208v030101p.pdf.
- [45] *What Could Slow RFID Adoption? | RFID JOURNAL*, <https://www.rfidjournal.com/what-could-slow-rfid-adoption>.
- [46] *EU Upper Band Country List*, en-US, <http://support.impinj.com/hc/en-us/articles/360006823440>.
- [47] «Publication: LEBENSMITTEL ZEITUNG LZ/NET NEWS», en, p. 2,
- [48] *Global RFID: The Value of the EPCglobal Network for Supply Chain Management | Request PDF*, en, https://www.researchgate.net/publication/273130979_Global_RFID_The_Value_of_the_EPCglobal_Network_for_Supply_Chain_Management.
- [49] *GS1 EPCglobal Architecture Framework v1.6 April 2014*, https://www.gs1.org/sites/default/files/docs/epc/architecture_1_6-framework-20140414.pdf.
- [50] *RFID Barcode Interoperability Guidelines.Pdf*, https://www.gs1.org/docs/barcodes/RFID_Barcode_Interoperability_Guidelines.pdf.
- [51] Dong-Ying Li, Shun-Dao Xie, R.-J. Chen, and H.-Z. Tan, «Design of Internet of Things System for Library Materials Management Using UHF RFID», in *2016 IEEE International Conference on RFID Technology and Applications (RFID-TA)*, Sep. 2016, pp. 44–48. DOI: 10.1109/RFID-TA.2016.7750755.
- [52] *EPC Tag Data Standard (TDS) v1.13*, https://www.gs1.org/sites/default/files/docs/epc/GS1_EPC_TDS_i1_13.pdf.
- [53] *UHF Gen2 Tag Air Interface v2.1.0*, https://www.gs1.org/sites/default/files/docs/epc/gs1-epc-gen2v2-uhf-airinterface_i21_r_2018-09-04.pdf.
- [54] *Low Level Reader Protocol (LLRP) v1.1*, https://www.gs1.org/sites/default/files/docs/epc/llrp_1_1-standard-20101013.pdf.
- [55] *Application Level Events (ALE) Specification v1.1.1 Part 1: Core*, https://www.gs1.org/sites/default/files/docs/epc/ale_1_1_1-standard-core-20090313.pdf.
- [56] *Application Level Events (ALE) Specification v1.1.1 Part 2: XML and SOAP Bindings*, https://www.gs1.org/sites/default/files/docs/epc/ale_1_1_1-standard-XMLandSOAPbindings-20090313.pdf.
- [57] «EPC Information Services (EPCIS) Version 1.0.1 Specification», en, p. 146,
- [58] *Core Business Vocabulary (CBV) Standard v1.2.2*, <https://www.gs1.org/sites/default/files/docs/epc/CBV-Standard-1-2-2-r-2017-10-12.pdf>.
- [59] *HF Class 1 Tag Air Interface v2.0.3*, https://www.gs1.org/sites/default/files/docs/epc/epcglobal_hf_2_0_3-standard-20110905r3.pdf.
- [60] *Reader Management (RM) v1.0.1*, https://www.gs1.org/sites/default/files/docs/epc/rm_1_0_1-standard-20070531.pdf.
- [61] *Discovery, Configuration, and Initialization (DCI) v1.0*, https://www.gs1.org/sites/default/files/docs/epc/dci_1_0-standard-20090610.pdf.
- [62] E. Tdt, T. WGs, and M. Harrison, *Tag Data Translation (TDT) v1.6*, en, https://www.gs1.org/sites/default/files/docs/epc/tdt_1_6-RatifiedStd-20111012-i2.pdf.
- [63] *Information Services (EPCIS) Standard v1.2*, <https://www.gs1.org/sites/default/files/docs/epc/EPCIS-Standard-1.2-r-2016-09-29.pdf>.
- [64] *Pedigree Standard v1.0 Jan 2007*, https://www.gs1.org/sites/default/files/docs/epc/pedigree_1_0-standard-20070105.pdf.

- [65] *EPCglobal Certificate Profile Specification 2.0*, en, https://www.gs1.org/sites/default/files/docs/cert/cert_2_0-standard-20100610.pdf.
- [66] K. Dean, *GS1 Object Name Service (ONS) v2.0.1*, en.
- [67] joe.horwood, *GDSN Standards Maintenance Release v3.1.14*, en, <https://www.gs1.org/standards/gdsn>, Text.
- [68] david.buckley, *GS1 Lightweight Verification Messaging*, en, <https://www.gs1.org/verification-messaging>, Text, Jan. 2019.
- [69] Anonymous, *GS1 Electronic Data Interchange (EDI) Standards*, en, <https://www.gs1.org/standards/edi>, Text, Dec. 2014.
- [70] david.buckley, *GS1 XML Standards 3.4.1*, en, <https://www.gs1.org/standards/gs1-xml/3-4-1>, Text, Nov. 2019.
- [71] I. Mizutani and J. Mitsugi, «A Multicode and Portable RFID Tag Events Emulator for RFID Information System», in *Proceedings of the 6th International Conference on the Internet of Things*, ser. IoT'16, New York, NY, USA: Association for Computing Machinery, 2016, pp. 187–188, ISBN: 978-1-4503-4814-0. DOI: 10.1145/2991561.2998470.
- [72] *RFID EPC Gen2 Memory Bank Layout Including TID, User*, en-US.
- [73] *TID Memory Maps for Monza Self-Serialization*, en-US, <https://support.impinj.com/hc/en-us/articles/203444983>.
- [74] ISO, *ISO/IEC 15962:2013*, en, <https://www.iso.org/cms/render/live/en/sites/isoorg/contents/data/standard/04/34/43459.html>.
- [75] marco.santos.diamond, *FAQ's*, en, <https://www.gs1.org/services/epc-encoder/faqs>, Text, Apr. 2020.
- [76] *GS1 General Specifications*, https://www.gs1.org/sites/default/files/docs/barcodes/GS1_General_Specifications.pdf.
- [77] M. Mealling <michael@refactored-networks.com>, *A Uniform Resource Name Namespace for the EPCglobal Electronic Product Code (EPC) and Related Standards*, en, <https://tools.ietf.org/html/rfc5134>.
- [78] *SGTIN INFO*, en-US.
- [79] *GS1 GTIN Executive Summary*, https://www.gs1.org/docs/idkeys/GS1_GTIN_Executive_Summary.pdf.
- [80] *GS1 GTIN Management Standard*, https://www.gs1.org/sites/default/files/docs/barcodes/GS1_GTIN_Management_Standard.pdf.
- [81] *GS1 Keys: Implementation Guidelines*, https://www.gs1.org/docs/tl/T_L_Keys_Implementation_Guideline.pdf.
- [82] *Barcode_GS1_General_Specifications.Pdf*, https://www.gs1.org/sites/default/files/docs/barcodes/GS1_General_Specifications.pdf.
- [83] *GS1 Barcode Chart*, https://www.gs1us.org/DesktopModules/Bring2mind/DMX/Download.aspx?Command=Core_Download&EntryId=160.
- [84] *Listing Requirements: Product IDs (GTINs) - Amazon Seller Central*, https://sellercentral.amazon.com/gp/help/external/200317470?language=en-US&ref=mpbc_200202190_cont_200317470.
- [85] Anonymous, *GS1 Company Prefix - ID Keys | GS1*, en, <https://www.gs1.org/standards/id-keys/company-prefix>, Text, Dec. 2014.
- [86] *Impinj LTK Programmers Guide*.
- [87] *RFID in Retail: The Key Benefits for Retailers and Customers*, en-US, <https://comparesoft.com/assets-tracking-software/retail/rfid-in-retail/>.

- [88] *EPCIS Guidelines*, https://www.gs1.org/docs/epc/EPCIS_Guideline.pdf.
- [89] *What You Need to Know About Smart Shelving Units*, en, <https://www.atlasrfidstore.com/rfid-insider/what-you-need-to-know-about-smart-shelving-units>.
- [90] *The Future of Retail: Shopping and the Smart Shelf*, en, <https://www.intel.com/content/www/us/en/retail/digital-retail-futurecasting-report.html>.
- [91] *Smart Shelves: A Key Component of Retail Digital Transformation*, en-US, <https://connect.altran.com/2019/11/smart-shelves-a-key-component-of-retail-digital-transformation/>, Nov. 2019.
- [92] *RFID Smart Cabinets For Medical Devices*, en-gb, <https://www.southwestsolutions.com/divisions/healthcare/rfid-medical-supply-inventory-system-smart-cabinets>.
- [93] *RFID Technology Cabinet - All Medical Device Manufacturers - Videos*, <https://www.medicalexpo.com/medical-manufacturer/rfid-technology-cabinet-43587.html>.
- [94] *Dyane SmartCabinet - Smart Cabinets with RFID Technology - Palex Medical*, <http://www.palexmedical.com/en/family.cfm?id=dyane%2Dsmartcabinet%2Dsmart%2Dcabinet>.
- [95] *RFID-Enabled Cabinetry*, en, <https://www.cardinalhealth.com/en/services/acute/pharmacy-services/specialty-distribution/consignment/rfid.html>.
- [96] *AdvanShelf : RFID Smart Shelf*, en-GB.
- [97] *RFID-Enabled Lockers Provide Total Accountability*, en-GB.
- [98] *AccuCab | Cribmaster.Com*, <https://www.cribmaster.com/products/accucab>.
- [99] *AccuDrawer | Cribmaster.Com*, <https://www.cribmaster.com/products/accudrawer>.
- [100] *RFID Rack - Fabmatics: Semiconductor Manufacturing Automation*, <https://www.fabmatics.com/products/storage/racks/rfid-rack/>.
- [101] *The Technology | WiseShelf*, en-US.
- [102] *Retail Solutions - AWM SMART SHELF*, https://smartshef.com/retail_solutions.html#led.
- [103] M. Sousa, J. Bezerra, E. Moreira, G. Barroso, A. Sérgio, and B. Sombra, «A SmartShelf with RFID for a Lean Supply System», May 2010. DOI: 10.13140/2.1.1310.7528.
- [104] S. C. Shieh, C. C. Lin, T. F. Yang, and G. H. Tu, «Using RFID Technology on Clinic’s Pharmacy Operation Management and Development of Intelligent Medicine Dispensing Cabinet», in *2008 IEEE International Conference on Industrial Engineering and Engineering Management*, Dec. 2008, pp. 2006–2009. DOI: 10.1109/IEEM.2008.4738223.
- [105] A. D’Alessandro, A. Buffi, P. Nepa, and G. Isola, «RFID-Based Smart Shelving Storage Systems», en, in *2012 Asia Pacific Microwave Conference Proceedings*, Kaohsiung, Taiwan: IEEE, Dec. 2012, ISBN: 978-1-4577-1332-3 978-1-4577-1330-9 978-1-4577-1331-6. DOI: 10.1109/APMC.2012.6421816.
- [106] C. R. Medeiros, C. C. Serra, C. A. Fernandes, and J. R. Costa, «UHF RFID Cabinet», in *2011 IEEE International Symposium on Antennas and Propagation (APSURSI)*, Jul. 2011, pp. 1429–1432. DOI: 10.1109/APS.2011.5996561.
- [107] C. E. M. Gomes, V. F. Lucena, F. Yazdi, and P. Göhner, «An Intelligent Medicine Cabinet Proposed to Increase Medication Adherence», in *2013 IEEE 15th International Conference on E-Health Networking, Applications and Services (Healthcom 2013)*, Oct. 2013, pp. 737–739. DOI: 10.1109/HealthCom.2013.6720776.
- [108] A. Zaric, C. C. Cruz, A. M. de Matos, M. R. da Silva, J. R. Costa, and C. A. Fernandes, «RFID-Based Smart Blood Stock System [Education Column]», *IEEE Antennas and Propagation Magazine*, vol. 57, no. 2, pp. 54–65, Apr. 2015, ISSN: 1558-4143. DOI: 10.1109/MAP.2015.2420491.
- [109] I. Markakis, T. Samaras, A. C. Polycarpou, and J. N. Sahalos, «An RFID-Enabled Library Management System Using Low-SAR Smart Bookshelves», in *2013 International Conference on Electromagnetics in Advanced Applications (ICEAA)*, Sep. 2013, pp. 227–230. DOI: 10.1109/ICEAA.2013.6632228.

- [110] —, «Safe and Efficient Design of the Shelf Antenna in an RFID-Based Library Management System», in *The 8th European Conference on Antennas and Propagation (EuCAP 2014)*, Apr. 2014, pp. 3185–3188. DOI: 10.1109/EuCAP.2014.6902505.
- [111] Ahmad Tarmizi Bin Abdullah, Ismarani Binti Ismail, Azlina Binti Ibrahim, and Mohd Zikrul Hakim Bin Noor, «Library Shelf Management System Using RFID Technology», in *2011 IEEE International Conference on System Engineering and Technology*, Jun. 2011, pp. 215–218. DOI: 10.1109/ICSEngT.2011.5993453.
- [112] K. Nishiyama, «A Smart Shelf, an Efficient Object Identification System by Blinking Led with Batteryless Passive Low Frequency RFID Tag», in *2012 International Symposium on Communications and Information Technologies (ISCIT)*, Oct. 2012, pp. 1144–1147. DOI: 10.1109/ISCIT.2012.6380865.
- [113] J. S. Choi, H. Lee, D. W. Engels, and R. Elmasri, «Passive UHF RFID-Based Localization Using Detection of Tag Interference on Smart Shelf», *IEEE Transactions on Systems, Man, and Cybernetics, Part C (Applications and Reviews)*, vol. 42, no. 2, pp. 268–275, Mar. 2012, ISSN: 1558-2442. DOI: 10.1109/TSMCC.2011.2119312.
- [114] P. Nikitin and K. Rao, «Theory and Measurement of Backscattering from RFID Tags», *Antennas and Propagation Magazine, IEEE*, vol. 48, pp. 212–218, Jan. 2007. DOI: 10.1109/MAP.2006.323323.
- [115] C. R. Medeiros, «UHF RFID Reader Antennas for Self-Confined TAG Detection», en, p. 10,
- [116] Y. Yuan and D. Yu, «UHF RFID Shelf Solution with Cascaded Reader Antenna and Positioning Capability», Apr. 2012. DOI: 10.1109/RFID.2012.6193043.
- [117] Y. Li, J. Yang, and P. Yang, «A CIRCULARLY POLARIZED COMPACT ANTENNA FOR UHF BAND RFID READER», 2013. DOI: 10.2528/PIERL13071509.
- [118] R. Caso, A. Michel, A. Buffi, P. Nepa, and G. Isola, «A Modular Antenna for UHF RFID Near-Field Desktop Reader», in *2014 IEEE RFID Technology and Applications Conference (RFID-TA)*, Sep. 2014, pp. 204–207. DOI: 10.1109/RFID-TA.2014.6934228.
- [119] A. Ren, C. Wu, T. Wang, and B. Yao, «A Novel Design for UHF Near-Field RFID Reader Antenna Based on Traveling Wave», in *2010 IEEE 12th International Conference on Communication Technology*, Nov. 2010, pp. 239–242. DOI: 10.1109/ICCT.2010.5689268.
- [120] A. Michel, A. Buffi, R. Caso, and P. Nepa, «A Scalable Modular Antenna Configuration to Extend the Detection Volume of a Near-Field UHF-RFID Desktop Reader», in *2015 IEEE International Symposium on Antennas and Propagation USNC/URSI National Radio Science Meeting*, Jul. 2015, pp. 1766–1767. DOI: 10.1109/APS.2015.7305272.
- [121] A. Michel, P. Nepa, and M. R. Pino, «An Overview on Modular Antennas for Near-Field UHF-RFID Systems», in *2016 IEEE International Conference on RFID Technology and Applications (RFID-TA)*, Sep. 2016, pp. 16–18. DOI: 10.1109/RFID-TA.2016.7750741.
- [122] A. Michel, A. Buffi, R. Caso, P. Nepa, G. Isola, and H. T. Chou, «Design and Performance Analysis of a Planar Antenna for Near-Field UHF-RFID Desktop Readers», in *2012 Asia Pacific Microwave Conference Proceedings*, Dec. 2012, pp. 1019–1021. DOI: 10.1109/APMC.2012.6421811.
- [123] P. Parthiban, B.-C. Seet, and X. J. Li, «Low-Cost Scalable UHF RFID Reader Antenna with No Surface Dead Zones», in *2016 IEEE Asia-Pacific Conference on Applied Electromagnetics (APACE)*, Dec. 2016, pp. 24–29. DOI: 10.1109/APACE.2016.7916432.
- [124] A. S. Andrenko and M. Kai, «Novel Design of UHF RFID Near-Field Antenna for Smart Shelf Applications», in *2013 Asia-Pacific Microwave Conference Proceedings (APMC)*, Nov. 2013, pp. 242–244. DOI: 10.1109/APMC.2013.6695107.
- [125] C. Cho, C. Lee, J. Ryoo, and H. Choo, «Planar Near-Field RFID Reader Antenna for Item-Level Tagging», *IEEE Antennas and Wireless Propagation Letters*, vol. 10, pp. 1100–1103, 2011, ISSN: 1548-5757. DOI: 10.1109/LAWP.2011.2169929.
- [126] E. Tolin, F. Vipiana, S. Bruni, and A. Bahr, «Polarization Reconfigurable Patch Antenna for Compact and Low Cost UHF RFID Reader», in *2019 IEEE International Conference on RFID Technology and Applications (RFID-TA)*, Sep. 2019, pp. 128–130. DOI: 10.1109/RFID-TA.2019.8892109.

- [127] P. Parthiban, B.-C. Seet, and X. J. li, «Scalable Near-Field Fed Far-Field UHF RFID Reader Antenna for Retail Checkout Counters», in *2019 IEEE International Conference on RFID (RFID)*, Apr. 2019, pp. 1–6. DOI: 10.1109/RFID.2019.8719097.
- [128] X. Chen, R. Huang, L. Shen, L. Liu, D. Xiong, X. Xiao, M. Liu, and X. Renheng, «The Design and Simulation of UHF RFID Microstrip Antenna», en, *IOP Conference Series: Earth and Environmental Science*, vol. 113, p. 012192, Feb. 2018, ISSN: 1755-1307, 1755-1315. DOI: 10.1088/1755-1315/113/1/012192.
- [129] W. Choi, J.-H. Bae, J.-S. Chae, and C.-W. Park, «U-Shaped Slot-Array Antenna for RFID Shelf in the UHF», in *2011 IEEE International Symposium on Antennas and Propagation (APSURSI)*, Jul. 2011, pp. 1449–1451. DOI: 10.1109/APS.2011.5996566.
- [130] X. Li, J. Sidén, and H. Andersson, «UHF RFID Shelf Reader Antennas for Object Classification and Distance Estimation of Non-Tagged RFID Objects», in *2017 IEEE International Conference on Microwaves, Antennas, Communications and Electronic Systems (COMCAS)*, Nov. 2017, pp. 1–4. DOI: 10.1109/COMCAS.2017.8244844.
- [131] Y. Yuan and D. Yu, «UHF RFID Shelf Solution with Cascaded Reader Antenna and Positioning Capability», in *2012 IEEE International Conference on RFID (RFID)*, Apr. 2012, pp. 149–156. DOI: 10.1109/RFID.2012.6193043.
- [132] G. Manzi, «Use of Transmission Lines as near Field Antenna in UHF RFID», in *2012 IEEE International Conference on RFID-Technologies and Applications (RFID-TA)*, Nov. 2012, pp. 319–322. DOI: 10.1109/RFID-TA.2012.6404538.
- [133] L. Catarinucci, R. Colella, M. De Blasi, L. Patrono, and L. Tarricone, «Improving Item-Level Tracing Systems through Ad Hoc UHF RFID Tags», in *2010 IEEE Radio and Wireless Symposium (RWS)*, Jan. 2010, pp. 160–163. DOI: 10.1109/RWS.2010.5434200.
- [134] X. Gu and W. Geyi, «Design of a Near-Field RFID Antenna Array in Metal Cabinet Environment», *IEEE Antennas and Wireless Propagation Letters*, vol. 18, no. 1, pp. 79–83, Jan. 2019, ISSN: 1548-5757. DOI: 10.1109/LAWP.2018.2880965.
- [135] A. Tzitzis, A. Filotheou, S. Siachalou, E. Tsardoulis, S. Megalou, A. Bletsas, K. Panayiotou, A. Symeonidis, T. Yioultsis, and A. G. Dimitriou, «Real-Time 3D Localization of RFID-Tagged Products by Ground Robots and Drones with Commercial off-the-Shelf RFID Equipment: Challenges and Solutions», in *2020 IEEE International Conference on RFID (RFID)*, Sep. 2020, pp. 1–8. DOI: 10.1109/RFID49298.2020.9244904.
- [136] C. Tang, Z. Tang, Y. Yang, and Y. Zhan, «Design of UHF RFID Reader Based on AS3991», in *2010 IEEE International Conference on RFID-Technology and Applications*, Jun. 2010, pp. 222–226. DOI: 10.1109/RFID-TA.2010.5529928.
- [137] Q. Lei, G. Wang, and D. Wang, «Design of a Handheld UHF RFID Reader for the Internet of Things», in *2011 International Conference on Computer and Management (CAMAN)*, May 2011, pp. 1–4. DOI: 10.1109/CAMAN.2011.5778747.
- [138] Y. Wang, N. Zhang, and L. Jin, «The Hardware Design and Implementation of Four-Channel UHF RFID Reader Based on Impinj R2000», in *2015 6th IEEE International Conference on Software Engineering and Service Science (ICSESS)*, Sep. 2015, pp. 565–568. DOI: 10.1109/ICSESS.2015.7339121.
- [139] H. M. O. de Miranda, «Sistemas RFID UHF», por, M.S. thesis, Universidade de Aveiro, 2015.
- [140] *Portugal recebe centro mundial de supply chain da Nespresso em 2019 – Logística Moderna*, pt-PT.
- [141] *RAIN RFID Reader Chips for the Internet of Things | Impinj*, en, <https://www.impinj.com/products/reader-chips>.
- [142] *RAIN RFID Partner Reader Modules | IMPINJ*, en, <https://www.impinj.com/products/partner-modules>.
- [143] *Press Release*, en, [_com/en/about/media-center/press-item.html/c2805.html](https://www.impinj.com/en/about/media-center/press-item.html/c2805.html).

- [144] M. Li and Y. Wu, «Design of Radio Frequency Circuit of Reader Based on AS3990», in *2011 IEEE 3rd International Conference on Communication Software and Networks*, May 2011, pp. 274–277. DOI: 10.1109/ICCSN.2011.6013591.
- [145] *ST25RU3993*, en, <https://www.st.com/en/nfc/st25ru3993.html>.
- [146] *UHF Mid Range Reader Module with Integrated Multiplexer - ID ISC.MRMU102*, en-GB, <https://www.feig.de/en/products/identification/product/id-iscrmu102/>.
- [147] *NUR Modules by Nordic ID: Build Your Own RFID Reader Solution*, en-US, <https://www.nordicid.com/device/modules/>.
- [148] *ThingMagic RFID*, en-US, <https://www.jadaktech.com/products/thingmagic-rfid/>.
- [149] *atlasRFIDstore | Buy RFID Technology | The RFID Hardware Experts*, <https://www.atlasrfidstore.com/>.
- [150] *Distribuidor de Componentes Eletrônicos - Mouser Electronics Europa*, <https://eu.mouser.com/>.
- [151] *Alien Technology Readers - Industry Leader in Ease of Use | Alien Technology*, en-US.
- [152] *Fosstrak LLRP Commander - LLRP Commander*, <https://fosstrak.github.io/llrp/>.
- [153] *Llrp.Org*, <http://llrp.org/tools.html>.
- [154] *Nike-Inc/Epc-Standards*, Nike Inc. Oct. 2019.
- [155] *Fosstrak - Tag Data Translation*, <https://fosstrak.github.io/tdt/index.html>.
- [156] *Open Language for Internet of Things (Oliot) by Gs1oliot*, <http://gs1oliot.github.io/oliot/>.
- [157] I. Mizutani, «Robust and High Performance RFID Middleware with Entropy Filtering», en, Ph.D. dissertation.
- [158] I. Mizutani and J. Mitsugi, «A Multicode and Portable RFID Tag Events Emulator for RFID Information System», in *Proceedings of the 6th International Conference on the Internet of Things*, ser. IoT'16, New York, NY, USA: Association for Computing Machinery, Nov. 2016, pp. 187–188, ISBN: 978-1-4503-4814-0. DOI: 10.1145/2991561.2998470.
- [159] I. Mizutani, *Iomz/Golemu*, Apr. 2020.
- [160] —, *Iomz/Gosstrak*, Feb. 2020.
- [161] *Global Trade & Supply Chains*, en, <https://www.iota.org/solutions/global-trade-and-supply-chains>.
- [162] *Fosstrak - Similar Projects*, <https://fosstrak.github.io/similar.html>.
- [163] *RECO-Bridge IDR-1 V2*, <https://industry.ricoh.com/rfid/recobridge/>.
- [164] *EasyTAP | Real Time Location Systems | Quake RFID Automation Processes*, <https://www.quakeglobal.com/products/easytap>.
- [165] *RFID “EasyTAP”(Tag Acquisition Processor)*, <https://www.tksl.co.jp/ja/products-info/technology-info/tap/index.html>.
- [166] *RIFIDI® Edge Server*, en-US, <http://transcends.co/rifidi-edge-server/>, Aug. 2015.
- [167] *Estante de Metal Stabil 176x160x60cm 280kg - Leroy Merlin Portugal*, https://www.leroymerlin.pt/Produtos/Arrumacao/estantes/metal/WPR_REF_17854242.
- [168] *Advantenna-P14 : RFID Compact RFID UHF Antenna*, en-GB.
- [169] *Seven RFID Organizations Support Open-Source Low-Level Reader Protocol Software Development*, en, <https://www.impinj.com/about-us/news-room/2016/seven-rfid-organizations-support-open-source>.
- [170] *Impinj | Soluções RAIN RFID para IoT sem limites*, pt, <https://www.impinj.com/pt>.

- [171] *Hid-Etiquetas-Rfid.Pdf*, <https://www.accurex.pt/images/hid-etiquetas-rfid.pdf>.
- [172] *Etusivu | IDcontrol*, <https://idcontrol.mycashflow.fi/>.
- [173] *Dvcorreia/Epc-Smart-Shelf*, en, <https://github.com/dvcorreia/epc-smart-shelf>.
- [174] *Fosstrak - Welcome*, <https://fosstrak.github.io/>.
- [175] *Octane SDK*, en-US, <https://support.impinj.com/hc/en-us/articles/202755268-Octane-SDK>.
- [176] *LTK XML for Java and C#*, en-US, <https://support.impinj.com/hc/en-us/articles/203855546-LTK-XML-for-Java-and-C->.
- [177] *Impinj Octane LLRP*.
- [178] *Setting Receive Sensitivity and Transmit Power on Revolution Reader Using LLRP*, en-US, <https://support.impinj.com/hc/en-us/articles/202756358-Setting-Receive-Sensitivity-and-Transmit-Power-on-Revolution-Reader-using-LLRP>.
- [179] *Reader Modes Made Easy*, en-US, <https://support.impinj.com/hc/en-us/articles/360000046899-Reader-Modes-Made-Easy>.
- [180] *Reader Mode 1002 – Autoset Dense Reader Deep Scan Overview*, en-US, <https://support.impinj.com/hc/en-us/articles/360007414920-Reader-Mode-1002-Autoset-Dense-Reader-Deep-Scan-Overview>.
- [181] *Understanding EPC Gen2 Search Modes and Sessions*, en-US, <https://support.impinj.com/hc/en-us/articles/202756158-Understanding-EPC-Gen2-Search-Modes-and-Sessions>.
- [182] *Fosstrak EPCIS - EPCIS Webadapter User Guide*, <https://fosstrak.github.io/epcis/docs/webadapter-guide.html>.
- [183] *React – A JavaScript Library for Building User Interfaces*, en, <https://reactjs.org/>.
- [184] *Ant Design - The World's Second Most Popular React UI Framework*, <https://ant.design/>.

Appendix

EPC SCHEMES AND CORRESPONDING GS1 KEYS

EPC Scheme	Tag Encodings	Corresponding GS1 key	Typical use
sgtin	sgtin-96 sgtin-198	GTIN key (plus added serial number)	Trade item
sscc	sscc-96	SSCC	Pallet load or other logistics unit load
sgln	sgln-96 sgln-195	GLN of physical location (with or without additional extension)	Location
grai	grai-96 grai-170	GRAI (serial number mandatory)	Returnable/reusable asset
giai	giai-96 giai-202	GIAI	Fixed asset
gsrn	gsrn-96	GSRN – Recipient	Hospital admission or club membership
gsrnp	gsrnp-96	GSRN for service provider	Medical caregiver or loyalty club
gdti	gdti-96 <i>gdti-113</i> (DEPRECATED) gdti-174	GDTI (serial number mandatory)	Document

Table 1: EPC Schemes and Corresponding GS1 keys Part 1 [52]

EPC Scheme	Tag Encodings	Corresponding GS1 key	Typical use
cpi	cpi-96 cpi-var	[none]	Technical industries (e.g. automotive) - components and parts
sgcn	sgcn-96	GCN (serial number mandatory)	Coupon
ginc	[none]	GINC	Logical grouping of goods intended for transport as a whole, assigned by a freight forwarder
gsin	[none]	GSIN	Logical grouping of logistic units travelling under one despatch advice and/or bill of lading
itip	itip-110 itip-212	(8006) + (21)	One of multiple pieces comprising, and subordinate to, a whole (which is, in turn, identified by an SGTIN or the combination of AIs 01 + 21).
upui	[none]	GTIN + TPX	Pack identification to combat illicit trade
pglN	[none]	Party GLN	Identification of economic operator; identification of owning party or possessing party in the Chain of Custody (CoC) / Chain of Ownership (CoO)
gid	gid-96	[none]	Unspecified
usdod	usdod-96	[none]	US Dept of Defense supply chain
adi	adi-var	[none]	Aerospace and defense – aircraft and other parts and items
bic	[none]	[none]	Intermodal shipping containers
imovN	[none]	[none]	Vessel identificaton

Table 2: EPC Schemes and Corresponding GS1 keys Part 2 [52]

LLRP MESSAGES

Message Name	Resp	Client/ Reader	Description
ADD_ACCESSSPEC	Y	C	Adds an <i>AccessSpec</i> to the reader
ADD_ROSPEC	Y	C	Adds an <i>ROSpec</i> to the Reader
CLIENT_REQUEST_OP	Y	R	Not supported by Impinj LTK
CLOSE_CONNECTION	Y	R	Reader generates this message before a client initiated connection closure
CUSTOM_MESSAGE	N/A	R or C	A custom message wrapper defined by LLRP to hold all custom message communication between the client and reader
DELETE_ACCESSSPEC	Y	C	Deletes an <i>AccessSpec</i> from the Reader
DELETE_ROSPEC	Y	C	Deletes an <i>ROSpec</i> from the Reader
DISABLE_ACCESSSPEC	Y	C	Disables an <i>AccessSpec</i> on the Reader
DISABLE_ROSPEC	Y	C	Disables an <i>ROSpec</i> on the Reader
ENABLE_ACCESSSPEC	Y	C	Enables an <i>AccessSpec</i> on the Reader

Table 3: LLRP Messages (except for responses) Part 1 [86]

Message Name	Resp	Client/ Reader	Description
ENABLE_EVENTS_- AND_REPORTS	N	C	A message generated by the client to enable the RO_ACCESS_REPORT and READER_EVENT_NOTIFICATION. Only required by client when using the <i>HoldEventsAndReports</i> feature of LLRP.
ENABLE_ROSPEC	Y	C	Enables an <i>ROSpec</i> on the Reader
ERROR_MESSAGE	N	R	A message generated by the Reader when it is unable to properly decode and respond to a client message.
GET_ACCESS_SPECS	Y	C	Gets the Reader's currently configured <i>AccessSpecs</i>
GET_READER_- CAPABILITIES	Y	C	Gets the Reader's capabilities
GET_READER_- CONFIG	Y	C	Gets the Reader's configuration
GET_REPORT	N	C	A message sent by the client to trigger a report to be generated from the Reader. This is in addition to any report triggers configured in the <i>ROSpec</i> or <i>AccessSpec</i> .
GET_ROSPECS	Y	C	Gets the Reader's currently configured <i>ROSpecs</i>
KEEP_ALIVE	Y	R	Reader periodically generates this message (when configured by the client). The response to this message generated by the client is called a <i>KEEP_ALIVE_ACK</i> (as opposed to the normal response nomenclature of LLRP)
READER_EVENT_- NOTIFICATION	N	R	A message generated by the reader to post asynchronous reader events (as opposed to tag events) to the client.
RO_ACCESS_REPORT	A	R	The report containing tag inventory and access data
SET_READER_CONFIG	Y	C	Sets the Reader configuration
START_ROSPEC	Y	C	Starts (activate) and <i>ROSpec</i> on the Reader
STOP_ROSPEC	Y	C	Stops (deactivates) an <i>ROSpec</i> on the Reader

Table 4: LLRP Messages (except for responses) Part 2 [86]

PRODUCTION DOCKER COMPOSE FILE

```
1  version: '3'
2  services:
3    middleware:
4      build: ./middleware
5      container_name: middleware
6      ports:
7        - "8080:8080"
8      volumes:
9        - ./middleware/logs/:/usr/local/tomcat/logs/
10     restart: on-failure
11   capture:
12     build: ./capture
13     container_name: capture
14     ports:
15       - "9999"
16     restart: on-failure
17     volumes:
18       -
19       ↪ ./capture/drools/:/usr/local/tomcat/webapps/capturingapp-0.1.1/WEB-INF/classes/drools/
20     depends_on:
21       - epcis
22   epcis:
23     build: ./epcis
24     container_name: epcis
25     ports:
26       - "8080"
27     volumes:
28       - ./epcis/logs/:/usr/local/tomcat/logs/
29     restart: always
30     depends_on:
31       - epcis-db
32   epcis-adapter:
33     build: ./epcis-adapter
34     container_name: epcis-adapter
35     restart: always
36   epcis-db:
37     image: mysql:5.6
38     container_name: epcis-db
39     command: --default-authentication-plugin=mysql_native_password
40     restart: always
41     environment:
42       - MYSQL_ROOT_PASSWORD=epcis
43       - MYSQL_DATABASE=epcis
44       - MYSQL_USER=epcis
45       - MYSQL_PASSWORD=epcis
46       - MYSQL_ALLOW_EMPTY_PASSWORD=yes
47     ports:
48       - "3306"
49     volumes:
```

```
49         - ./epcis-db/files/:/docker-entrypoint-initdb.d
50         - ./epcis-db/data/:/var/lib/mysql
51     web:
52         image: nginx:alpine
53         volumes:
54             - ./web/build/:/usr/share/nginx/html
55         restart: always
56     proxy:
57         image: nginx:latest
58         container_name: proxy
59         ports:
60             - "80:80"
61         volumes:
62             - ./default.conf:/etc/nginx/conf.d/default.conf
63         depends_on:
64             - web
65             - epcis-adapter
```

OCTANE SDK READER CONFIGURATION PROGRAM

```
1 package main;
2
3 import com.impinj.octane.*;
4 import org.apache.log4j.Logger;
5 import java.util.Scanner;
6
7 /**
8  * Configures Reader with Octane SDK and saves / loads local configurations
9  */
10 public final class App {
11     private static final Logger log = Logger.getLogger(App.class);
12
13     private static Settings configReader(ImpinjReader reader) throws Exception {
14         Settings settings = reader.queryDefaultSettings();
15
16         ReportConfig report = settings.getReport();
17         report.setIncludeAntennaPortNumber(true);
18
19         // The reader will collect and coalesce tag reports and send them the the
20         // current operation completes and the reader stops
21         report.setMode(ReportMode.BatchAfterStop);
22
23         settings.getAutoStart().setMode(AutoStartMode.Periodic);
24         settings.getAutoStart().setPeriodInMs(5000);
25         settings.getAutoStop().setMode(AutoStopMode.Duration);
26         settings.getAutoStop().setDurationInMs(5000);
27
28         // A refinement of AutoSetDenseReaderDeepScan, targeted toward static
29         // environments where difficult to read tags are expected and we are ready to
30         // sacrifice performance to ensure that they are read
31         settings.setReaderMode(ReaderMode.AutoSetDenseReaderDeepScan);
32
33         // Single Target Inventory with Suppression (aka TagFocus)
34         settings.setSearchMode(SearchMode.TagFocus);
35         settings.setSession(1);
36
37         // Setup filtering
38
39         // this will match the company prefix of the target EPC with "76300544"
40         String matchingMask1 = "91882001";
41         TagFilter t1 = settings.getFilters().getTagFilter1();
42         t1.setBitCount(27);
43         t1.setBitPointer(BitPointers.Epc + 14);
44         t1.setMemoryBank(MemoryBank.Epc);
45         t1.setFilterOp(TagFilterOp.Match);
46         t1.setTagMask(matchingMask1);
47
48         // this will match the company prefix of the target EPC with "76300396"
49         String matchingMask2 = "91880D82";
```

```

50     TagFilter t2 = settings.getFilters().getTagFilter2();
51     t2.setBitCount(27);
52     t2.setBitPointer(BitPointers.Epc + 14);
53     t2.setMemoryBank(MemoryBank.Epc);
54     t2.setFilterOp(TagFilterOp.Match);
55     t2.setTagMask(matchingMask2);
56
57     settings.getFilters().setMode(TagFilterMode.Filter1OrFilter2);
58
59     // set some special settings for antenna 1
60     AntennaConfigGroup antennas = settings.getAntennas();
61     antennas.disableAll();
62     antennas.enableById(new short[] { 1 });
63     antennas.getAntenna((short) 1).setIsMaxRxSensitivity(false);
64     antennas.getAntenna((short) 1).setIsMaxTxPower(false);
65     antennas.getAntenna((short) 1).setTxPowerinDbm(30.0);
66     antennas.getAntenna((short) 1).setRxSensitivityinDbm(-80);
67
68     return (settings);
69 }
70
71 public static void main(String[] args) {
72     try {
73         String hostname = System.getProperty("hostname");
74         String saveSettings = System.getProperty("saveSettings");
75
76         if (hostname == null) {
77             throw new Exception("Must specify the 'hostname' property");
78         }
79
80         ImpinjReader reader = new ImpinjReader();
81
82         log.info("Connecting to Reader at " + hostname + System.lineSeparator());
83         reader.connect(hostname);
84
85         Settings settings = configReader(reader);
86         if (saveSettings != null) {
87             log.info("Saving reader configuration in /reader_settings.json ...");
88             settings.save("./reader_settings.json");
89         }
90
91         // Listener provided in SDK sample code
92         reader.setTagReportListener(new TagReportListenerImplementation());
93
94         log.info("Applying Settings to Reader ..." + System.lineSeparator());
95         reader.applySettings(settings);
96
97         log.info("Starting readings ..." + System.lineSeparator());
98         reader.start();
99

```

```
100     log.info("Press Enter to exit." + System.lineSeparator());
101     Scanner s = new Scanner(System.in);
102     s.nextLine();
103
104     s.close();
105
106     log.info("Removing tag report listener ...");
107     reader.removeTagReportListener();
108     log.info("Disconnecting from reader ...");
109     reader.disconnect();
110     log.warn("RO_SPEC is still active ...");
111     log.info("Exited with success!");
112 } catch (OctaneSdkException ex) {
113     log.error(ex.getMessage());
114 } catch (Exception ex) {
115     log.error(ex.getMessage());
116     // ex.printStackTrace(System.out);
117 }
118 }
119 }
```

XML READER CONFIGURATION MESSAGE FILES

```
1 <?xml version="1.0"?>
2 <SET_READER_CONFIG xmlns="http://www.llrp.org/ltk/schema/core/encoding/xml/1.0"
  ↳ xmlns:llrp="http://www.llrp.org/ltk/schema/core/encoding/xml/1.0"
  ↳ xmlns:xsi="http://www.w3.org/2001/XMLSchema-instance"
  ↳ xmlns:Impinj="http://developer.impinj.com/ltk/schema/encoding/xml/1.4"
  ↳ xsi:schemaLocation="http://www.llrp.org/ltk/schema/core/encoding/xml/1.0
  ↳ http://www.llrp.org/ltk/schema/core/encoding/xml/1.0/llrp.xsd
  ↳ http://developer.impinj.com/ltk/schema/encoding/xml/1.4
  ↳ http://developer.impinj.com/ltk/schema/encoding/xml/1.4/impinj.xsd" Version="1"
  ↳ MessageID="3">
3   <ResetToFactoryDefault>>false</ResetToFactoryDefault>
4   <AntennaConfiguration>
5     <AntennaID>0</AntennaID>
6     <RFReceiver>
7       <ReceiverSensitivity>1</ReceiverSensitivity>
8     </RFReceiver>
9     <RFTransmitter>
10      <HopTableID>1</HopTableID>
11      <ChannelIndex>1</ChannelIndex>
12      <TransmitPower>81</TransmitPower>
13    </RFTransmitter>
14    <C1G2InventoryCommand>
15      <TagInventoryStateAware>>false</TagInventoryStateAware>
16      <C1G2RFControl>
17        <ModeIndex>1002</ModeIndex>
18        <Tari>0</Tari>
19      </C1G2RFControl>
20      <!-- <Impinj:ImpinjInventorySearchMode>
21        <Impinj:InventorySearchMode>Dual_Target</Impinj:InventorySearchMode>
22      </Impinj:ImpinjInventorySearchMode> -->
23    </C1G2InventoryCommand>
24  </AntennaConfiguration>
25 </SET_READER_CONFIG>
```



```

1  <?xml version="1.0" encoding="UTF-8"?>
2  <ADD_ROSPEC xmlns="http://www.llrp.org/ltk/schema/core/encoding/xml/1.0" Version="1"
   ↪  MessageID="0">
3    <ROSpec>
4      <ROSpecID>666</ROSpecID>
5      <Priority>0</Priority>
6      <CurrentState>Disabled</CurrentState>
7      <ROBoundarySpec>
8        <ROSpecStartTrigger>
9          <ROSpecStartTriggerType>Periodic</ROSpecStartTriggerType>
10         <PeriodicTriggerValue>
11           <Offset>0</Offset>
12           <Period>5000</Period>
13         </PeriodicTriggerValue>
14       </ROSpecStartTrigger>
15       <ROSpecStopTrigger>
16         <ROSpecStopTriggerType>Duration</ROSpecStopTriggerType>
17         <DurationTriggerValue>2000</DurationTriggerValue>
18       </ROSpecStopTrigger>
19     </ROBoundarySpec>
20     <AISpec>
21       <AntennaIDs>0</AntennaIDs>
22       <AISpecStopTrigger>
23         <AISpecStopTriggerType>Null</AISpecStopTriggerType>
24         <DurationTrigger>0</DurationTrigger>
25       </AISpecStopTrigger>
26       <InventoryParameterSpec>
27         <InventoryParameterSpecID>1</InventoryParameterSpecID>
28         <ProtocolID>EPCGlobalClass1Gen2</ProtocolID>
29       </InventoryParameterSpec>
30     </AISpec>
31     <ROReportSpec>
32       <ROReportTrigger>Upon_N_Tags_Or_End_Of_ROSpec</ROReportTrigger>
33       <N>0</N>
34       <TagReportContentSelector>
35         <EnableROSpecID>1</EnableROSpecID>
36         <EnableSpecIndex>0</EnableSpecIndex>
37         <EnableInventoryParameterSpecID>0</EnableInventoryParameterSpecID>
38         <EnableAntennaID>0</EnableAntennaID>
39         <EnableChannelIndex>0</EnableChannelIndex>
40         <EnablePeakRSSI>0</EnablePeakRSSI>
41         <EnableFirstSeenTimestamp>1</EnableFirstSeenTimestamp>
42         <EnableLastSeenTimestamp>1</EnableLastSeenTimestamp>
43         <EnableTagSeenCount>0</EnableTagSeenCount>
44         <EnableAccessSpecID>0</EnableAccessSpecID>
45       </TagReportContentSelector>
46     </ROReportSpec>
47   </ROSpec>
48 </ADD_ROSPEC>

```

READER CAPABILITIES FROM *GET_READER_CAPABILITIES_RESPONSE*
MESSAGE

```
1  <?xml version="1.0" encoding="UTF-8"?>
2  <llrp:GET_READER_CAPABILITIES_RESPONSE
   ↳ xmlns:llrp="http://www.llrp.org/ltk/schema/core/encoding/xml/1.0" Version="1"
   ↳ MessageID="0">
3    <llrp:LLRPStatus>
4      <llrp:StatusCode>M_Success</llrp:StatusCode>
5      <llrp:ErrorDescription />
6    </llrp:LLRPStatus>
7    <llrp:GeneralDeviceCapabilities>
8      <llrp:MaxNumberOfAntennaSupported>1</llrp:MaxNumberOfAntennaSupported>
9      <llrp:CanSetAntennaProperties>0</llrp:CanSetAntennaProperties>
10     <llrp:HasUTCClockCapability>1</llrp:HasUTCClockCapability>
11     <llrp:DeviceManufacturerName>25882</llrp:DeviceManufacturerName>
12     <llrp:ModelName>2001009</llrp:ModelName>
13     <llrp:ReaderFirmwareVersion>6.2.1.240</llrp:ReaderFirmwareVersion>
14     <llrp:ReceiveSensitivityTableEntry>
15       <llrp:Index>1</llrp:Index>
16       <llrp:ReceiveSensitivityValue>0</llrp:ReceiveSensitivityValue>
17     </llrp:ReceiveSensitivityTableEntry>
18     <llrp:ReceiveSensitivityTableEntry>
19       <llrp:Index>2</llrp:Index>
20       <llrp:ReceiveSensitivityValue>10</llrp:ReceiveSensitivityValue>
21     </llrp:ReceiveSensitivityTableEntry>
22     ...
23     <llrp:ReceiveSensitivityTableEntry>
24       <llrp:Index>41</llrp:Index>
25       <llrp:ReceiveSensitivityValue>49</llrp:ReceiveSensitivityValue>
26     </llrp:ReceiveSensitivityTableEntry>
27     <llrp:ReceiveSensitivityTableEntry>
28       <llrp:Index>42</llrp:Index>
29       <llrp:ReceiveSensitivityValue>50</llrp:ReceiveSensitivityValue>
30     </llrp:ReceiveSensitivityTableEntry>
31     <llrp:GPIOCapabilities>
32       <llrp:NumGPIOs>4</llrp:NumGPIOs>
33       <llrp:NumGPOs>4</llrp:NumGPOs>
34     </llrp:GPIOCapabilities>
35     <llrp:PerAntennaAirProtocol>
36       <llrp:AntennaID>1</llrp:AntennaID>
37       <llrp:ProtocolID>EPCGlobalClass1Gen2</llrp:ProtocolID>
38     </llrp:PerAntennaAirProtocol>
39   </llrp:GeneralDeviceCapabilities>
40   <llrp:LLRPCapabilities>
41     <llrp:CanDoRFSurvey>0</llrp:CanDoRFSurvey>
42     <llrp:CanReportBufferFillWarning>1</llrp:CanReportBufferFillWarning>
43     <llrp:SupportsClientRequestOpSpec>0</llrp:SupportsClientRequestOpSpec>
44
45     ↳ <llrp:CanDoTagInventoryStateAwareSingulation>0</llrp:CanDoTagInventoryStateAwareSingulation>
     <llrp:SupportsEventAndReportHolding>1</llrp:SupportsEventAndReportHolding>
```

```

46 <llrp:MaxNumPriorityLevelsSupported>1</llrp:MaxNumPriorityLevelsSupported>
47 <llrp:ClientRequestOpSpecTimeout>0</llrp:ClientRequestOpSpecTimeout>
48 <llrp:MaxNumROSpecs>1</llrp:MaxNumROSpecs>
49 <llrp:MaxNumSpecsPerROSpec>32</llrp:MaxNumSpecsPerROSpec>
50
51 ↵ <llrp:MaxNumInventoryParameterSpecsPerAISpec>1</llrp:MaxNumInventoryParameterSpecsPerAISpec>
52 <llrp:MaxNumAccessSpecs>1508</llrp:MaxNumAccessSpecs>
53 <llrp:MaxNumOpSpecsPerAccessSpec>8</llrp:MaxNumOpSpecsPerAccessSpec>
54 </llrp:LLRPCapabilities>
55 <llrp:RegulatoryCapabilities>
56 <llrp:CountryCode>0</llrp:CountryCode>
57 <llrp:CommunicationsStandard>ETSI_302_208</llrp:CommunicationsStandard>
58 <llrp:UHFBandCapabilities>
59 <llrp:TransmitPowerLevelTableEntry>
60 <llrp:Index>1</llrp:Index>
61 <llrp:TransmitPowerValue>1000</llrp:TransmitPowerValue>
62 </llrp:TransmitPowerLevelTableEntry>
63 <llrp:TransmitPowerLevelTableEntry>
64 <llrp:Index>2</llrp:Index>
65 <llrp:TransmitPowerValue>1025</llrp:TransmitPowerValue>
66 </llrp:TransmitPowerLevelTableEntry>
67 ...
68 <llrp:TransmitPowerLevelTableEntry>
69 <llrp:Index>80</llrp:Index>
70 <llrp:TransmitPowerValue>2975</llrp:TransmitPowerValue>
71 </llrp:TransmitPowerLevelTableEntry>
72 <llrp:TransmitPowerLevelTableEntry>
73 <llrp:Index>81</llrp:Index>
74 <llrp:TransmitPowerValue>3000</llrp:TransmitPowerValue>
75 </llrp:TransmitPowerLevelTableEntry>
76 <llrp:FrequencyInformation>
77 <llrp:Hopping>0</llrp:Hopping>
78 <llrp:FixedFrequencyTable>
79 <llrp:Frequency>865700 866300 866900 867500</llrp:Frequency>
80 </llrp:FixedFrequencyTable>
81 </llrp:FrequencyInformation>
82 <llrp:C1G2UHFRFModeTable>
83 <llrp:C1G2UHFRFModeTableEntry>
84 <llrp:ModeIdentifier>2</llrp:ModeIdentifier>
85 <llrp:DRValue>DRV_64_3</llrp:DRValue>
86 <llrp:EPCHAGTCConformance>0</llrp:EPCHAGTCConformance>
87 <llrp:MValue>MV_4</llrp:MValue>
88 <llrp:ForwardLinkModulation>PR_ASK</llrp:ForwardLinkModulation>
89 <llrp:SpectralMaskIndicator>DI</llrp:SpectralMaskIndicator>
90 <llrp:BDRValue>320000</llrp:BDRValue>
91 <llrp:PIEValue>2000</llrp:PIEValue>
92 <llrp:MinTariValue>20000</llrp:MinTariValue>
93 <llrp:MaxTariValue>20000</llrp:MaxTariValue>
94 <llrp:StepTariValue>0</llrp:StepTariValue>
</llrp:C1G2UHFRFModeTableEntry>

```

```

95 <llrp:C1G2UHFRFModeTableEntry>
96   <llrp:ModeIdentifier>3</llrp:ModeIdentifier>
97   <llrp:DRValue>DRV_64_3</llrp:DRValue>
98   <llrp:EPCHAGTCConformance>0</llrp:EPCHAGTCConformance>
99   <llrp:MValue>MV_8</llrp:MValue>
100  <llrp:ForwardLinkModulation>PR_ASK</llrp:ForwardLinkModulation>
101  <llrp:SpectralMaskIndicator>DI</llrp:SpectralMaskIndicator>
102  <llrp:BDRValue>32000</llrp:BDRValue>
103  <llrp:PIEValue>2000</llrp:PIEValue>
104  <llrp:MinTariValue>20000</llrp:MinTariValue>
105  <llrp:MaxTariValue>20000</llrp:MaxTariValue>
106  <llrp:StepTariValue>0</llrp:StepTariValue>
107 </llrp:C1G2UHFRFModeTableEntry>
108 <llrp:C1G2UHFRFModeTableEntry>
109   <llrp:ModeIdentifier>5</llrp:ModeIdentifier>
110   <llrp:DRValue>DRV_64_3</llrp:DRValue>
111   <llrp:EPCHAGTCConformance>0</llrp:EPCHAGTCConformance>
112   <llrp:MValue>MV_4</llrp:MValue>
113   <llrp:ForwardLinkModulation>PR_ASK</llrp:ForwardLinkModulation>
114   <llrp:SpectralMaskIndicator>MI</llrp:SpectralMaskIndicator>
115   <llrp:BDRValue>32000</llrp:BDRValue>
116   <llrp:PIEValue>2000</llrp:PIEValue>
117   <llrp:MinTariValue>14290</llrp:MinTariValue>
118   <llrp:MaxTariValue>14290</llrp:MaxTariValue>
119   <llrp:StepTariValue>0</llrp:StepTariValue>
120 </llrp:C1G2UHFRFModeTableEntry>
121 <llrp:C1G2UHFRFModeTableEntry>
122   <llrp:ModeIdentifier>1000</llrp:ModeIdentifier>
123   <llrp:DRValue>DRV_8</llrp:DRValue>
124   <llrp:EPCHAGTCConformance>0</llrp:EPCHAGTCConformance>
125   <llrp:MValue>MV_FMO</llrp:MValue>
126   <llrp:ForwardLinkModulation>PR_ASK</llrp:ForwardLinkModulation>
127   <llrp:SpectralMaskIndicator>Unknown</llrp:SpectralMaskIndicator>
128   <llrp:BDRValue>40000</llrp:BDRValue>
129   <llrp:PIEValue>1500</llrp:PIEValue>
130   <llrp:MinTariValue>6250</llrp:MinTariValue>
131   <llrp:MaxTariValue>6250</llrp:MaxTariValue>
132   <llrp:StepTariValue>0</llrp:StepTariValue>
133 </llrp:C1G2UHFRFModeTableEntry>
134 <llrp:C1G2UHFRFModeTableEntry>
135   <llrp:ModeIdentifier>1002</llrp:ModeIdentifier>
136   <llrp:DRValue>DRV_8</llrp:DRValue>
137   <llrp:EPCHAGTCConformance>0</llrp:EPCHAGTCConformance>
138   <llrp:MValue>MV_FMO</llrp:MValue>
139   <llrp:ForwardLinkModulation>PR_ASK</llrp:ForwardLinkModulation>
140   <llrp:SpectralMaskIndicator>Unknown</llrp:SpectralMaskIndicator>
141   <llrp:BDRValue>40000</llrp:BDRValue>
142   <llrp:PIEValue>1500</llrp:PIEValue>
143   <llrp:MinTariValue>6250</llrp:MinTariValue>
144   <llrp:MaxTariValue>6250</llrp:MaxTariValue>

```

```
145     <llrp:StepTariValue>0</llrp:StepTariValue>
146   </llrp:C1G2UHFRFModeTableEntry>
147 </llrp:C1G2UHFRFModeTable>
148 </llrp:UHFBandCapabilities>
149 </llrp:RegulatoryCapabilities>
150 <llrp:C1G2LLRPCapabilities>
151   <llrp:CanSupportBlockErase>0</llrp:CanSupportBlockErase>
152   <llrp:CanSupportBlockWrite>1</llrp:CanSupportBlockWrite>
153   <llrp:MaxNumSelectFiltersPerQuery>5</llrp:MaxNumSelectFiltersPerQuery>
154 </llrp:C1G2LLRPCapabilities>
155 </llrp:GET_READER_CAPABILITIES_RESPONSE>
```

IMPINJ READERS SEARCH MODES

Value	Name	Typical Use Case	What it does
0	Reader Selected		Reader selected mode (default)
1	Single Target Inventory	High tag count, high-throughput use cases where a reduction in repeated tag observation is acceptable.	Inventories tags in state A, transitioning the tags to state B
2	Dual Target Inventory	Low-to-medium tag count, low-throughput use cases where repeated tag observation is desirable.	Inventories tags in state A, transitioning the tags to state B Inventories tags in state B, transitioning the tags back to state A
3	Single Target Inventory with Suppression (aka TagFocus)	High tag count, high-throughput use cases where a reduction in repeated tag observations is acceptable. Suppresses repeated observations for extended periods of time while tags are energized. Supported only with Monza tags using Session 1	Inventories tags in state A, transitioning the tags to state B Tags will persist in state B if they are energized Tags will transition to state A in <= 5 seconds when de-energized
4	Reserved for future use		
5	Single Target Reset Inventory	Used in conjunction with 'Single Target Inventory' to achieve higher throughput when using Sessions 2 and 3 that have longer decay intervals.	Inventories tags in state B, transitioning the tags to state A
6	Dual Target Inventory with Reset	High tag count, high-throughput use cases where repeated tag observation is desirable	Inventories tags in state A, transitioning the tags to state B Sends Gen2 Select command to transition tags back to state A
> 6	Reserved for future use		

Table 5: Impinj Readers Search Modes [177]

COMPLEX SMART SHELVES SOLUTION ECSPEC

```

1  <?xml version="1.0" encoding="UTF-8"?>
2  <ns2:ECSpec xmlns:ns2="urn:epcglobal:ale:xsd:1">
3    <logicalReaders>
4      <logicalReader>Reader</logicalReader>
5    </logicalReaders>
6    <boundarySpec>
7      <repeatPeriod unit="MS">20000</repeatPeriod>
8      <duration unit="MS">5000</duration>
9      <stableSetInterval unit="MS">0</stableSetInterval>
10   </boundarySpec>
11   <!--3 ECRports delivered to the capture application-->
12   <reportSpecs>
13     <!--Sends a report informing the added trading cases for transport (filter = 2)
14     ↪ with filter rules for nespresso company prefixes (76300544 and 76300396)-->
15     <reportSpec reportName="additions">
16       <reportSet set="ADDITIONS" />
17       <filterSpec>
18         <extension>
19           <filterList>
20             <filter>
21               <includeExclude>INCLUDE</includeExclude>
22               <fieldspec>
23                 <fieldname>epc</fieldname>
24               </fieldspec>
25               <patList>
26                 <pat>urn:epc:tag:sgtin-96:2:76300544.*.*</pat>
27                 <pat>urn:epc:tag:sgtin-96:2:76300396.*.*</pat>
28               </patList>
29             </filter>
30           </filterList>
31         </extension>
32       </filterSpec>
33       <output includeTag="true" />
34     </reportSpec>
35     <!--Sends a report informing the removed trading cases for transport (filter = 2)
36     ↪ with filter rules for nespresso company prefixes (76300544 and 76300396)-->
37     <reportSpec reportName="deletions">
38       <reportSet set="DELETIONS" />
39       <filterSpec>
40         <extension>
41           <filterList>
42             <filter>
43               <includeExclude>INCLUDE</includeExclude>
44               <fieldspec>
45                 <fieldname>epc</fieldname>
46               </fieldspec>
47               <patList>
48                 <pat>urn:epc:tag:sgtin-96:2:76300544.*.*</pat>
49                 <pat>urn:epc:tag:sgtin-96:2:76300396.*.*</pat>

```

```

48         </patList>
49     </filter>
50 </filterList>
51 </extension>
52 </filterSpec>
53 <output includeTag="true" />
54 </reportSpec>
55 <!--Sends a report informing the current state of sleeves inventory (filter = 1
    ↳ point of sale) with filter rules for nespresso company prefixes (76300544 and
    ↳ 76300396)-->
56 <!--The report aggregates the tags based on unique products and countS them. The
    ↳ report only contains an inventory of how many sleeves of each coffee type are
    ↳ in inventory-->
57 <reportSpec reportName="inventory">
58     <reportSet set="CURRENT" />
59     <filterSpec>
60         <extension>
61             <filterList>
62                 <filter>
63                     <includeExclude>INCLUDE</includeExclude>
64                     <fieldspec>
65                         <fieldname>epc</fieldname>
66                     </fieldspec>
67                     <patList>
68                         <pat>urn:epc:tag:sgtin-96:1:76300544.*.*</pat>
69                         <pat>urn:epc:tag:sgtin-96:1:76300396.*.*</pat>
70                     </patList>
71                 </filter>
72             </filterList>
73         </extension>
74     </filterSpec>
75     <groupSpec>
76         <pattern>urn:epc:tag:sgtin-96:1.X.X.*</pattern>
77     </groupSpec>
78     <output includeCount="true" />
79 </reportSpec>
80 </reportSpecs>
81 </ns2:ECSpec>

```

PARTIAL EPCIS DATA MODEL IN GOLANG

```
1 package main
2
3 import (
4     "encoding/xml"
5 )
6
7 // Envelope is the Soap app root tag in the response
8 type Envelope struct {
9     XMLName xml.Name `xml:"Envelope" json:"- "`
10    Body    body    `xml:"Body"`
11 }
12
13 // EPCISQueryDocument is the root tag in the subscription post requests
14 type EPCISQueryDocument struct {
15     XMLName    xml.Name    `xml:"EPCISQueryDocument" json:"- "`
16     EPCISBody  epcisbody  `xml:"EPCISBody"`
17 }
18
19 type epcisbody struct {
20     XMLName    xml.Name    `xml:"EPCISBody" json:"- "`
21     QueryResults queryResults `xml:"QueryResults"`
22 }
23
24 type body struct {
25     XMLName    xml.Name    `xml:"Body" json:"- "`
26     QueryResults queryResults `xml:"QueryResults"`
27 }
28
29 type queryResults struct {
30     XMLName    xml.Name    `xml:"QueryResults" json:"- "`
31     SubscriptionID string    `xml:"subscriptionID,omitempty"
32     ↵ json:"subscriptionID,omitempty"`
33     QueryName    string    `xml:"queryName" json:"queryName"`
34     ResultsBody  resultsBody `xml:"resultsBody" json:"resultsBody"`
35 }
36
37 type resultsBody struct {
38     XMLName    xml.Name    `xml:"resultsBody" json:"- "`
39     EventList  eventList  `xml:"EventList"`
40 }
41
42 type eventList struct {
43     XMLName    xml.Name    `xml:"EventList" json:"- "`
44     ObjectEvents []objectEvent `xml:"ObjectEvent"`
45 }
46
47 type objectEvent struct {
48     XMLName    xml.Name    `xml:"ObjectEvent" json:"- "`
49     EventTime  string    `xml:"eventTime" json:"eventTime"`
```

```

49     RecordTime      string      `xml:"recordTime" json:"recordTime"`
50     EventTimeZoneOffSet string    `xml:"eventTimeZoneOffset"
    ↪ json:"eventTimeZoneOffset"`
51     EpcList          epcList   `xml:"epcList" json:"epcList"`
52     Action           string     `xml:"action" json:"action"`
53     BizStep          string     `xml:"bizStep" json:"bizStep"`
54     Disposition      string     `xml:"disposition" json:"disposition"`
55     ReadPoint        readPoint `xml:"readPoint" json:"readPoint"`
56     BizLocation      bizLocation `xml:"bizLocation" json:"bizLocation"`
57 }
58
59 type epclist struct {
60     XMLName xml.Name `xml:"epcList" json:"- "`
61     Epcs     []string `xml:"epc" json:"epc"`
62 }
63
64 type readPoint struct {
65     XMLName xml.Name `xml:"readPoint" json:"- "`
66     ID      []string `xml:"id" json:"id"`
67 }
68
69 type bizLocation struct {
70     XMLName xml.Name `xml:"bizLocation" json:"- "`
71     ID      []string `xml:"id" json:"id"`
72 }

```

Errata (9 February 2021)

This document contains a few corrections detected in the dissertation document.

1. Page 85, figure 7.3 - The script generating the graph was not indexing a column and a line of the data. The fixed graph looks like the following:

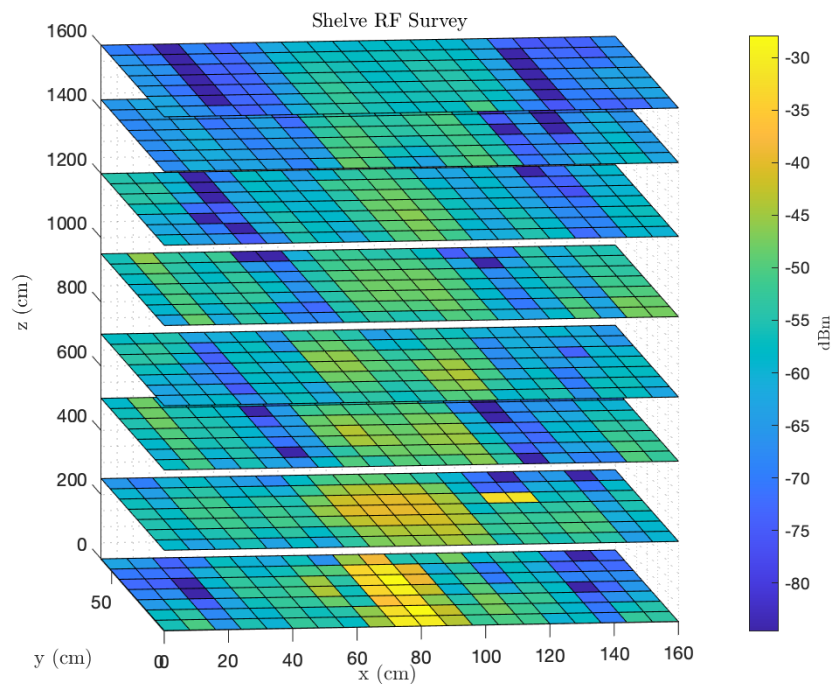

2. Page 87, section 7.4.1: Problems - It was not stated how the implications detected in the previous test of the "Singulation Stress Test", section 7.3, affected the operation of the shelf. When a population of tags was placed in a zone affected by obstructions, a tag would occasionally miss read for a few seconds, creating a false detection of changes in the inventory.